

## TURBOJET HL-39 ASSEMBLY AND DEBUGGING GUIDE

V1.0

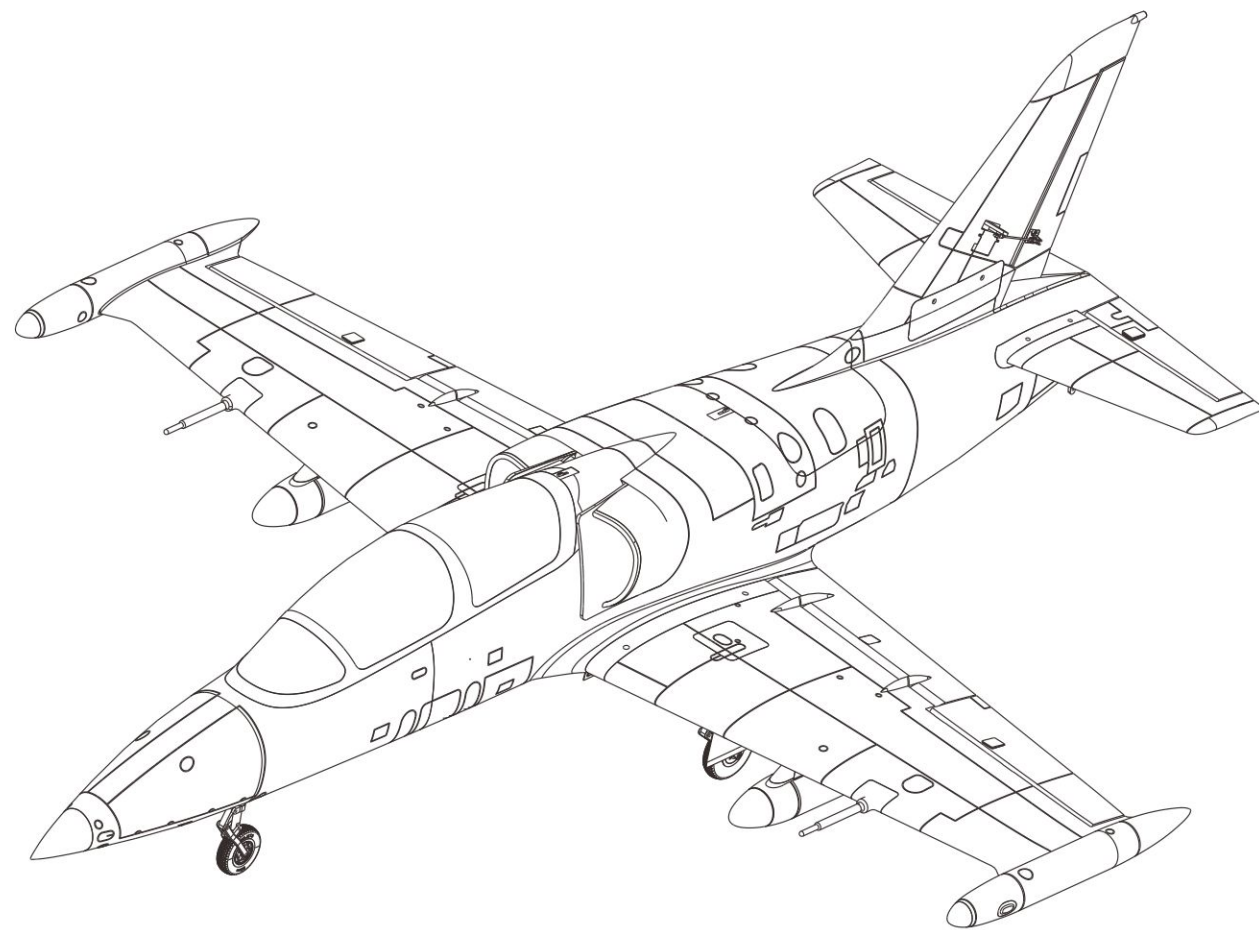

Product S/N:

Want to learn more about the product video,  
pictures, and other matters of attention Please  
log in: [www.hsdr.com](http://www.hsdr.com)

## INDEX

Introduction-----	03
Important hints-----	03
Safety Instructions-----	04
Description of each component -----	08
Install instructions: 1. Open the box(PNP version)-----	09
Install instructions: 2. Install the Nose and the Fuselage-----	10
Install instructions: 3. Install the left and right Horizontal tail-----	10
Install instructions: 4. Install the vertical tail-----	11
Install instructions: 5. Install the auxiliary fuel tank-----	11
Install instructions: 6. Install the main wing-----	11
First test and adjustment after assembly: 1-5. Startup process-----	12
First test and adjustment after assembly: 6. Aileron test-----	12
First test and adjustment after assembly: 7. Aileron adjustment-----	13
First test and adjustment after assembly: 8. Elevation test-----	13
First test and adjustment after assembly: 9. Elevation adjustment-----	14
First test and adjustment after assembly: 10. Direction test-----	14
First test and adjustment after assembly: 11. Direction adjustment-----	15
First test and adjustment after assembly: 12. Flap test-----	16
First test and adjustment after assembly: 13. Flaps adjustment-----	16
First test and adjustment after assembly: 14. Reduction plate test-----	17
First test and adjustment after assembly: 15. Reduction plate adjustment-----	17
First test and adjustment after assembly: 16. Landing gear test and adjustment-----	18
First test and adjustment after assembly: 17. Ground test and adjustment-----	19
First test and adjustment after assembly: 18. Pre-takeoff center of gravity test-----	20
First test and adjustment after assembly: 19. Center of gravity adjustment-----	20
landing gear decomposition graph-----	21
Specification and configuration-----	23

## Introduction

Thank you so much for purchasing HL-39 Jet plane, What you have now is the latest HL-39 Jet plane product of HSDJETS. This model has the following features:

- 01.Scale appearance with a classic look and attention to detail with state of the art electronics.
- 02.The Airframe is constructed of 20 times ultra high-density and high-strength EPO foam. this makes for a very durable aircraft that resist many not so welcomed occasions!
- 03.HSDJETS has invested in the independent development of an exclusive control system to fully integrate the landing gear, various channel servos, power, lighting and other systems to reduce complicated wiring.
- 04.The integral main wing has carbon fiber rod and glass fiber rib frame embedded inside the main wing. The strength of the integral main wing is obviously improved and the torsion resistance is stronger.
- 05.With Biconvex airfoil, the lift coefficient is large, so that HL-39 can easily control the aircraft to a stable flight attitude at low speed.
- 06.This HL-39 utilizes 13 Precision All Metal Gear Digital Servos for much better precision, reliability, power and strength!
- 07.Sequencing on-board LED Lighting System gives the HL-39 an

extremely scale appearance.

- 08.The Tail Afterburner has a Full Ring of LED lights that will increase in intensity and decrease intensity with your throttle stick input! Giving the HL-39 an After Burner Glow that is just awesome to watch!
- 09.Featuring an all new Anti-Bubble Fuel Tank design and built-in fuel filter. This will greatly and more effectively prevent air bubbles from entering the Engine and may cause a Flame Out.
- 10.All new wing plug design for easy wing attachment using high quality plug materials for reliability and ease.
- 11.Two reinforcement bar inside the fuselage in order to leading the connection between the wings and the fuselage, meanwhile, level up the overall strength of wings and fuselage.
- 12.The connection mode between front and rear electric retractors and landing gear is updated. The original 5 mm diameter fixed axle is cancelled. The 11 mm diameter landing gear leg is locked directly in the electric slot, so that the landing gear leg can withstand stronger impact and is not easy to bend.

We believe that HL-39 Jet plane will bring you excellent flight. Before starting, please read our manual carefully.

## Note



**This is not a toy, it has the potentially dangerous, not for children under 14 years old. Young people under the age of 14 should only be permitted to operate the model under the instruction and supervision of an adult. Please keep these instructions for further reference after completing model assembly.**

## Important hints

1. Operator should have a certain experience, beginners should operate under the guidance of professional players;
2. Before install, please read through the instructions carefully and operate strictly under instructions;
3. Cause of wrong operation, HSDJETS and its distributors/dealers will not be held responsibility for any losses;
4. Model planes players must be above the age of 14 years old;
5. This plane used the EPO material with surface spray paint, don't use chemical liquid to clean, otherwise it will damage;
6. Your should be careful to avoid flying in areas such as public places, high-voltage-intensive areas, near the highway, near the airport of any other place where laws and regulation clearly prohibit;
7. You can not fly in bad weather conditions such as thunderstorms, snow, and etc;
8. Model plane`s battery, don`t allowed to put in everywhere. Storage must ensure that there is no inflammable and explosive materials in the round of 2 meter range;
9. Damaged or scrap battery should be properly recycled, it can`t discard to avoid spontaneous combustion and fire;
10. In flying field, the waste after flying should be properly handled, it can`t be abandoned or burned;
11. In any case, you must ensure that the throttle is in the low position and transmitter switch on, then it can connect the li-po battery in aircraft;
- 12.Do not try to take planes by hand when flying or slow landing process. You must wait for landing stop and when the blades stop turning, first disconnect the power supply and than carry it;
- 13.Whether flying or debugging on the ground, always ensure that there is no one in front of the aircraft.

## Safety Instructions

**Strongly suggestion: users while enjoying the flying, please ensure that you are in a safe and reasonable environment.**

1. It is better to try to choose an empty airspace and no obstacles conditions when you fly.
2. Stay away from people, animals, buildings, trees, water and other obstacles during flying.
3. Please keep the radio transmitter in your hand during the flight to control the model at any time to prevent accidents.
4. Please control the height of the aircraft to 120 meters to ensure the flight safety of the flyer and civil aviation. If you are in the area that have restrictions on flying altitude of 120 meters or less, please comply with its regulations. Make sure the model do not go out of sight and cause unnecessary accidents.

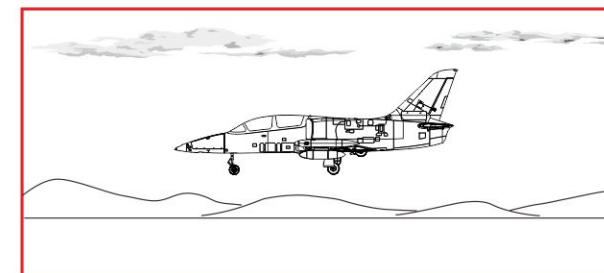

**120m**

## Flight environment requirements

1. Do not fly in areas such as transmission towers, communication base stations, high-voltage lines, or Wi-Fi hotspots to prevent the radio transmitter signal is interferenced.
2. Do not operate in bad weather, such as: strong winds(wind speed 10 m/s and above), raining, lightning, fog, snow, etc..
3. Flying is not recommended at altitudes above 4,500 meters and in the Arctic and Arctic circles.
4. Do not fly in airports or restricted areas under the relevant laws or regulations.

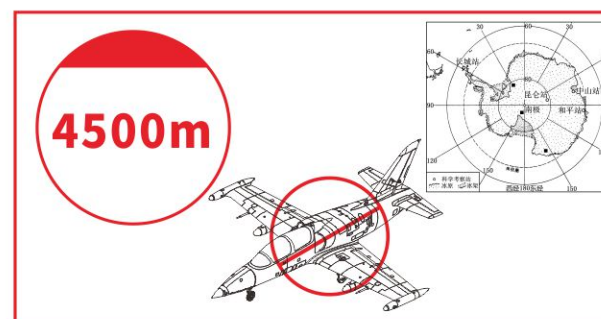
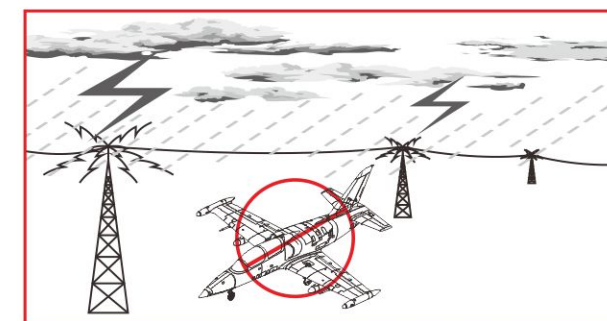
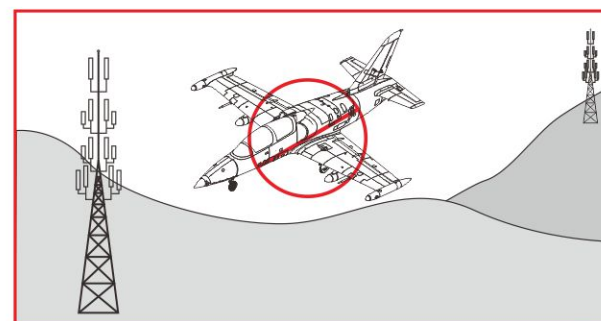

## Warm Prompt

The use life of the turbine is directly related to the operation environment and operation methods. The turbine uses the most streamlined structure to achieve the most extreme working state. Each spare part is designed and produced in the extreme, and the working conditions are extremely harsh.

Do not dismantle the inlet and spindle structures by yourself. In case the turbine is dismantled, it must be re-installed in accordance with the specifications to achieve the original performance. Arbitrary assembly will cause the turbojet body to lose balance, and high-speed operation will cause serious consequences.

## Safety Instructions

※ Please be sure to read the following safety instructions and prepare the emergency equipment before operation.

The micro-turbine is only use on the aircraft moel. The operating state of the turbine is in a high speed and high temperature, which is quite dangerous. Users must read the product instructions before using the turbine. be familiar with the operation procedures of various functions, and understand the safety risks that may result from wrong operations. Wrong operations or parameter settings may cause damage to the engine equipment and endanger to the personal safety. Please strict compliance with product operation regulations.

※ If you are operating the turbojet engine for the first time, please work with someone with experience.

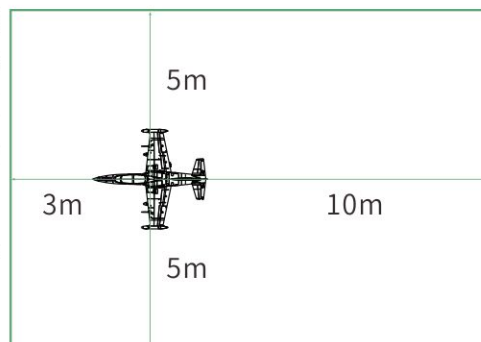

### 1. Safe distance

The turbine works at a very high speed. All persons must keep a safe distance to the turbine when it is running. The turbine must keep a distance of three meters in front of it. A distance of five meters in the left and right sides, and a distance of ten meters should be kept in the rear due to there is high temperature and heat from the tail pipe.

## Safety Instructions

### 2. Personal Safety Protection and Fire Emergency Equipment

Carbon dioxide extinguishers should be prepared at any time and placed within 2 meters of the engine. In case of danger, persons present can use it immediately. Dry powder fire extinguisher is strictly prohibited. If the powder is sprayed into the turbine, it will cause serious wear and tear of the turbine. Suggesting to use of soundproof earmuffs and goggles. The soundproof earmuffs can block the huge sound pressure and prevent hearing damage. After filling the turbine tank with fuel, the fuel equipment must be placed at a distance out of three meters. The goggles can prevent oil or foreign bodies from splashing.

#### Prepare fire extinguisher or powerful hairdryer and earmuffs.

Carbon dioxide extinguishers or the turbine dedicated power Hairdryer should be prepared at any time, and use earmuffs to block the huge sound pressure to prevent hearing damage.



Dry powder fire extinguisher is strictly prohibited. If the powder is sprayed into the turbine, it will cause serious wear and tear of the turbine.

### 3. Turbine fuel and specialized lubricants

The kerosene or diesel oil can be used in the turbine, must mix with 5 % turbine special lubricant regardless when you use one of each of them. We recommend the use of Mobil Pegasus II turbojet special lubricant.

1 L = 0.8 kg, one pot mix with 20 L(16 kg)



## Safety Instructions

### 4. Other security matters

※ When the engine is running, the air intake is like the vacuum. Do not draw your hand close to the air intake of the engine to prevent it from being inhaled. The air intake should be kept clear and the signal transmission wire should be properly fixed.



※ The engine inlet is suggested to be equipped with protective isolation net to prevent serious damage to the engine caused by foreign bodies.

※ There will be a large amount of high temperature heat when the engine is working, and the exhaust temperature can be as high as 650 °C. Please pay attention to the insulation and protection measures of the surrounding equipment.



※ It is absolutely forbidden to start the turbine indoors. When the turbine is working, it will consume a lot of oxygen. It may cause suffocation of indoor personnel. The hot air and strong air flow that are discharged may ignite dry inflammable materials and blow debris.

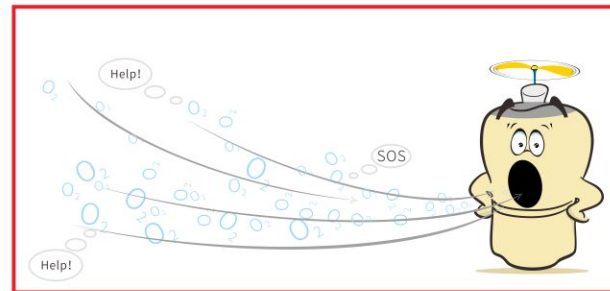

※ The turbine jet's flying speed is extremely fast. It is necessary to pay attention to the distance of the operating airspace and the safety of civilian buildings and personnel and vehicles on the ground.

※ The turbine jet can easily reach speeds above 300km/h. Therefore, it is necessary to pay attention to the reliability of the aircraft's rudder surface. It is recommended that the aircraft should be equipped with wing deceleration or wheel braking equipment.



※ The AMA Association of the United States has a maximum speed limit of 320km/hr.

### Special tip:

The service life of the turbine jet will be directly affected by the operate environment and operate mode. The turbine jet uses the most streamlined structure to achieve the most extreme operating state. Each spare part is designed and produced with high precision, and the rotating parts have undergone high-speed dynamic balance correction, as the working conditions are therefore extremely demanding. Users should not dismantle the turbine. Once the turbine is dismantled, it must be re-installed in accordance with the specifications to achieve the original performance. Arbitrary disassembly / assembly will cause the turbine body to lose balance. High speed operation can cause the leaf disintegration or damage to the combustion chamber or other severe consequences.

\* Turbine manufacturers also do not provide any product safety and maintenance guarantees for users to disassemble / assemble by themselves.

## Description of each component

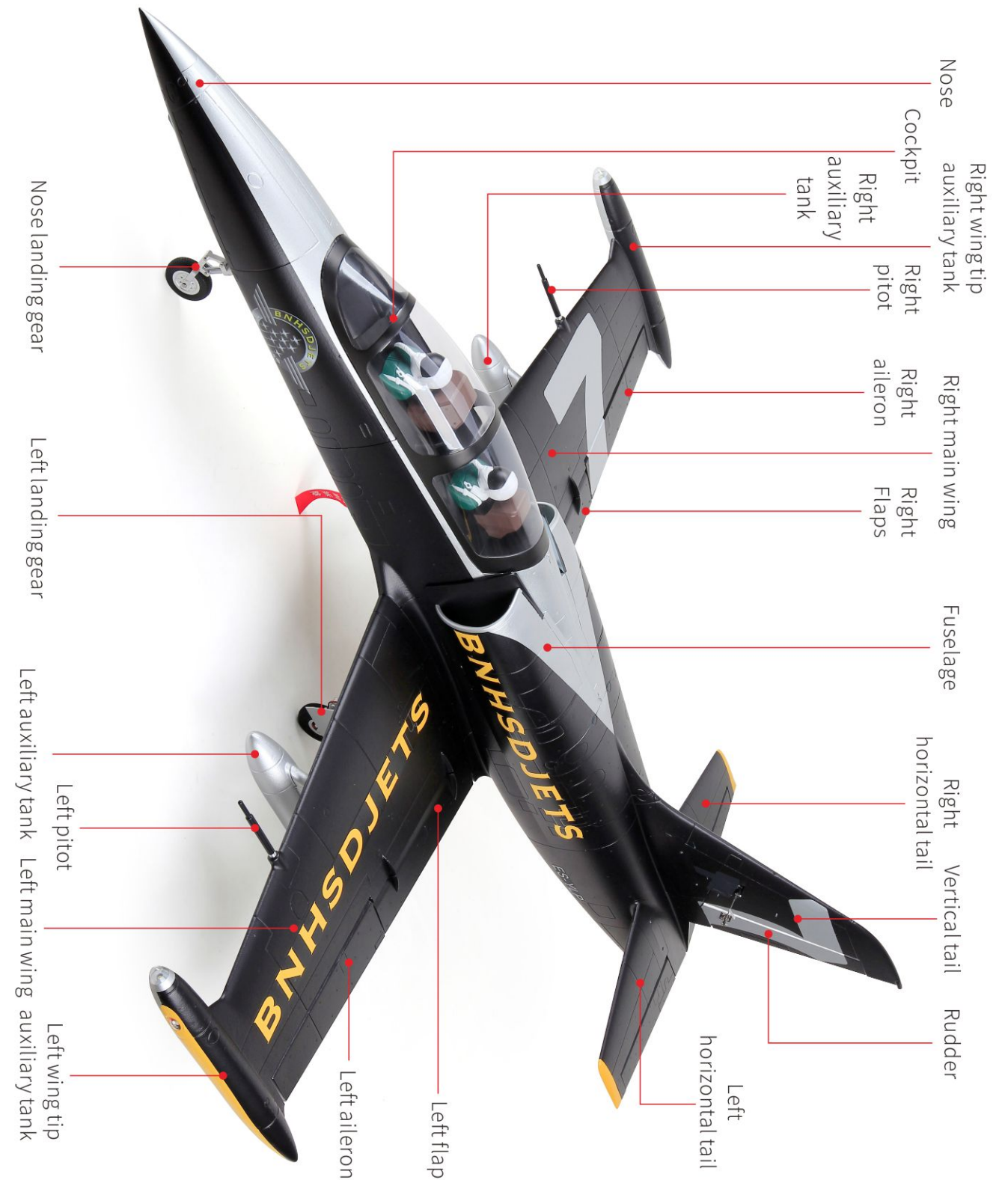

## Install instructions

**1. Open the box(PNP version):** Take out the Fuselage, Left and right main wings, Nose, Cockpit, Vertical tail, left and right Horizontal tail, Left and right auxiliary tanks, Manuals, Main wing and horizontal tail pin rods, Accessory kits and other items, and check whether the quantity of the packaged items is complete according to the list of packaged items in the manual.



Fuselage×1



Right main wing×1



Left main wing×1



Nose×1



Cockpit×1



Vertical tail ×1



Left horizontal tail×1



Right horizontal tail×1



Auxiliary tank ×1

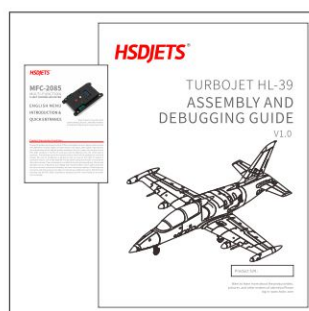

Manual×1

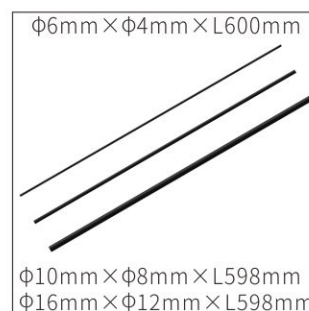

Φ6mm×Φ4mm×L600mm

Φ10mm×Φ8mm×L598mm

Φ16mm×Φ12mm×L598mm

Pin rod×1

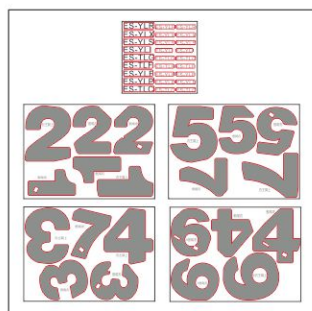

Decal×1

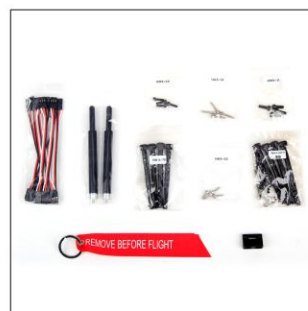

Accessories package×1

PNP:	KIT:
HM3×10mm×8pcs	HM3×10mm×8pcs
HA3×10mm×8pcs	HA3×10mm×12pcs
HA3×14mm×8pcs	HA3×14mm×8pcs
HM4×10mm×8pcs	HM4×10mm×8pcs
PWM6×70mm×8pcs	PWM6×70mm×8pcs

Screw information

## Install instructions

**2. Install the Nose and the Fuselage:** Take out the Nose and Fuselage from the PE bag, place them on a flat and clean table, align the four screw holes of the head with the corresponding four screw holes of the Fuselage, and fix them with screws (HM6 × 70mm × 4pcs). Then connect the signal cables at the head end and the fuselage end respectively. The color of the wire is opposite to the color and cannot be reversed. Note: if you want to be more firm, you can apply EPO glue to the contact section between the head and the fuselage before fixing the screws. (Note: the color of the wire must be right for the color of the signal cable, and it cannot be reversed.)

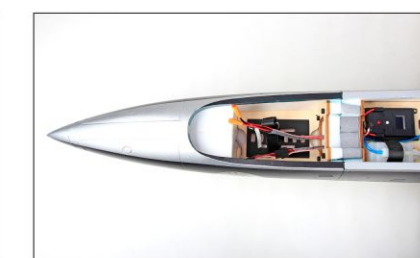
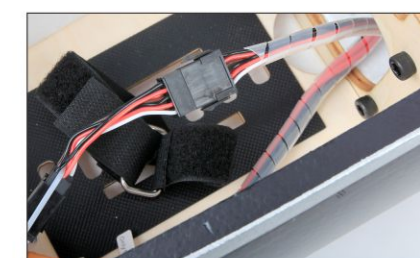
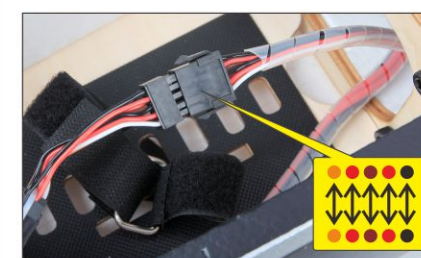

**3. Install the left and right Horizontal tail:** Take out the left and right flat tail and flat tail reinforcing rods from the PE bag and place them on the flat and clean table. First, pass the flat tail reinforcing rod (Φ 6mm × Φ 4mm × L600mm) through the designated hole position of the fuselage to ensure that the extension length of the flat tail reinforcing rods at the left and right ends of the fuselage is equal. Then, align the hole positions of the left and right flat tail with the reinforcing rods respectively, insert the reinforcing rods, install the left and right flat tail in place, and then use the screws (HM3 × 10mm × 4pcs).



## Install instructions

**4. Install the vertical tail:** Take out the vertical tail from the PE bag, install the vertical tail in the designated position of the fuselage, and make sure to connect the vertical tail end and the fuselage end signal cable; fix both sides with screws (HA3 × 10 mm × 4pcs) after installation.



**5. Install the auxiliary fuel tank:** Take out the auxiliary oil tank from the PE bag, install the auxiliary oil tank at the designated position of the wing, push back at the leading edge of the wing, hear a sound, indicating that it is installed in place.

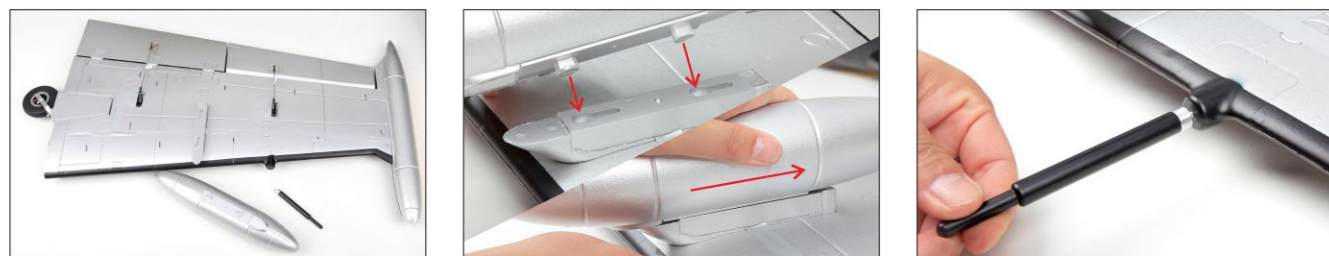

**6. Install the main wing:** Pass the main wing stiffener (φ16mm × φ12mm × L598mm) (φ 10mm × φ 8mm × L598mm) through the designated hole position of the fuselage, make sure that the extension length of the main wing stiffener at the left and right ends of the fuselage is equal, then align the hole position of the left and right main wings with the main wing stiffener, and insert the stiffener. Before fully inserting, make sure that the signal line between the main wing end and the fuselage end is connected, and then fix it with screws (HM4 × 10mm × 4pcs), L39 body assembly is completed.



## First test and adjustment after assembly



1. To find the S-BUS line at the location of the Super Integrated Control Box and connected to the receiver S-BUS port. (Note: If the receiver does not support S-BUS, the integrated control box needs to be connected to the PWM signal line connection;)

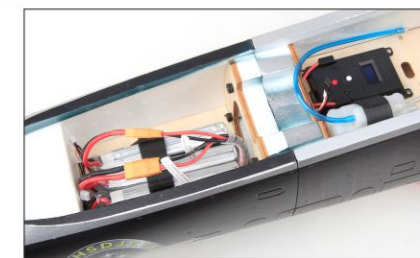

2. Connect the Super integrated control box with 2 sets of 2S lipo batteries;



3. Open the radio transmitter.



4. Super integrated control box start up. (For details on start up operations, kindly see the MFC-2085 multi-function flight controller system english menu introduction & quick entrance)

5. Check the Super Integrated Control Box S-BUS mode channel settings. The factory default channel is: S-BUS Setting

(Note: You can change the default gear switch position according to your own custom channel.)

- |                                  |                                     |
|----------------------------------|-------------------------------------|
| 1.AUX1 CH Aileron (default CH1)  | 7.AUX7 CH Smoke(default CH7)        |
| 2.AUX2 CH Elevator (default CH2) | 8.AUX8 CH Spare                     |
| 3.AUX3 CH Rudder (default CH4)   | 9.A/B LIGHT CH (default CH3)        |
| 4.AUX4 CH Flap (default CH6)     | 10.REDUCTION PLATE CH (default CH9) |
| 5.AUX5 CH Spare                  | 11.WHEEL BRAKE CH (default CH8)     |
| 6.AUX6 CH Throttle (default CH3) | 12.LANDING GEAR CH (default CH5)    |

**6. Aileron test:** Check whether the aileron action is correct

Right model throttle radio transmitter



Aileron standard action

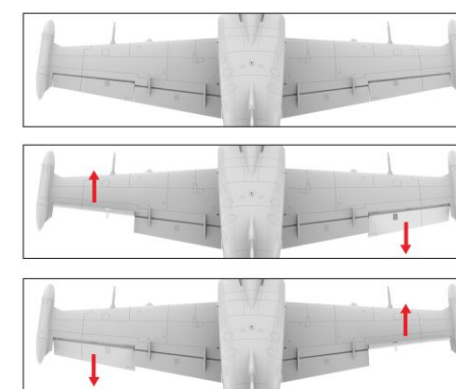

Possible ailerons reverse action

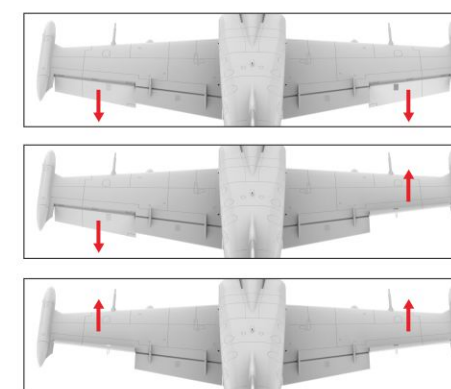

Note: If there is no special explanation, this user guide is introduced by default with the right model throttle radio transmitter as an example.

When the aileron action is opposite to the specified action, you can adjust it with the 2 ways as below:

- (1). to find the reverse setting menu of servo in the radio transmitter menu, and switch in the aileron item to the forward direction.
- (2). Adjust directions of the aileron servo through the Super integrated control box (for details, pls see the MFC-2085 multi-function flight controller system english menu introduction & quick entrance);

## First test and adjustment after assembly

**7. Aileron adjustment:** After the setting, the standard position of the rudder surface will be adjusted. The aileron rudder surface should be in the same plane as the wing. If there is an upward or downward adjustment, it can be adjusted by physical adjustment or system adjustment;

(1). Physical adjustment: by adjusting the length of the pull rod to change the rudder surface angle to keep it in the same plane as the wing;

(2). System Adjustment: Adjust the neutral point of the servo through the Super integrated control box (for details, pls see the MFC-2085 multi-function flight controller system english menu introduction & quick entrance);

It is recommended to adjust the radio transmitter travel to 80% , adjusting the EXP curve under the same amount of servo, it recommends to adjust to -30 % EXP value in the first time; Can adjust according to the personal operating habits.



Suggest the amount of servo:

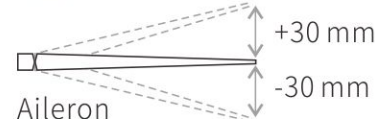

EXP Recommend: -30%

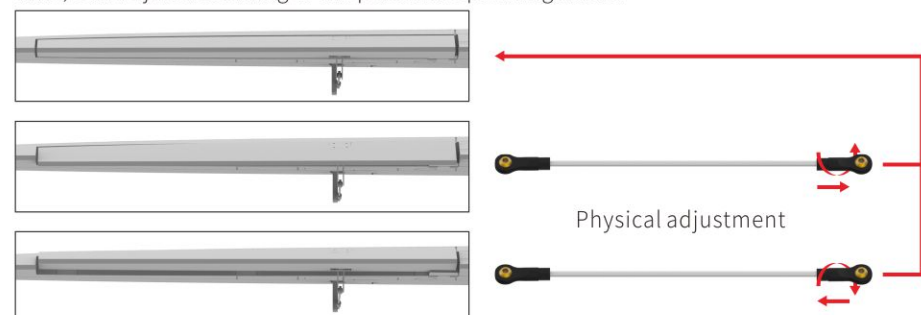

**8. Elevation test:** Check whether the elevate action is correct

Right model throttle radio transmitter



Elevation standard action

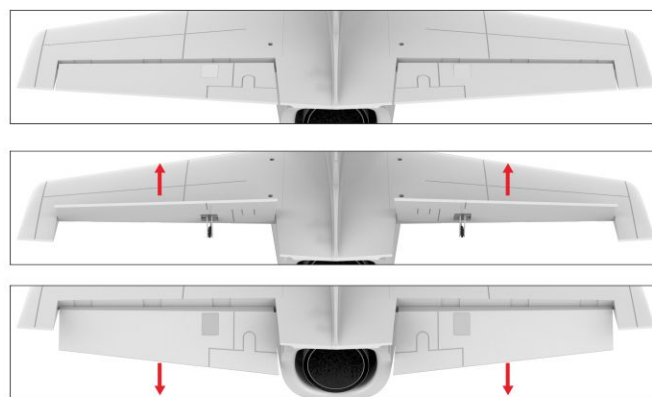

Note: If there is no special explanation, this user guide is introduced by default with the right model throttle radio transmitter as an example.

Possible elevation reverse action

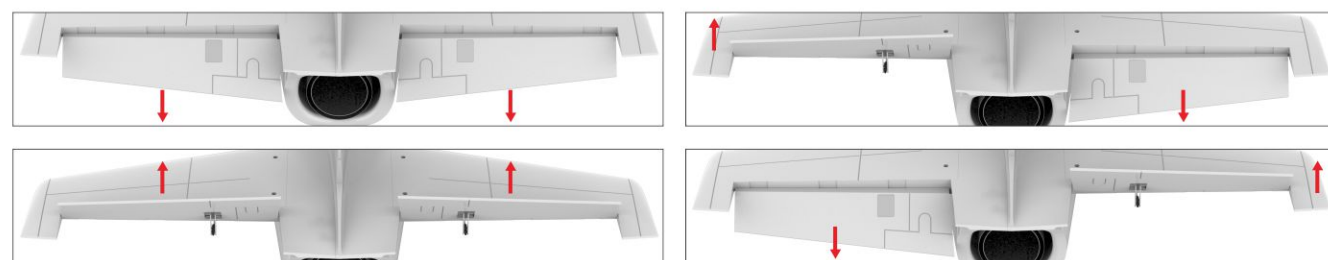

When the elevate action is opposite to the specified action, you can adjust it with the 2 ways as below:

- (1). to find the reverse setting menu of servo in the radio transmitter menu, and switch in the elevate item to the forward direction.
- (2). Adjust directions of the elevate servo through the Super integrated control box (for details, pls see the MFC-2085 multi-function flight controller system english menu introduction & quick entrance);

## First test and adjustment after assembly

**9. Elevation adjustment:** After the setting, the standard position of the rudder surface will be adjusted. The rear edge of elevator should be flush with the upper edge of the fuselage as the benchmark . If there is an upward or downward adjustment, it can be adjusted by physical adjustment or system adjustment;

(1). Change the angle of the rudder surface by adjusting the length of the pull rod, so that the rear edge of the elevator is in a plane with the upper edge of the fuselage ;

(2). System Adjustment: Adjust the neutral point of the servo through the Super integrated control box (for details, pls see the MFC-2085 multi-function flight controller system english menu introduction & quick entrance);

It is recommended to adjust the radio transmitter travel to 80%, adjusting the EXP curve under the same amount of servo, it recommends to adjust to -30 % EXP value in the first time; Can adjust according to the personal operating habits.



Suggest the amount of servo:



EXP Recommend: -30%



**10. Direction test:** Check whether the direction action is correct

Direction standard action

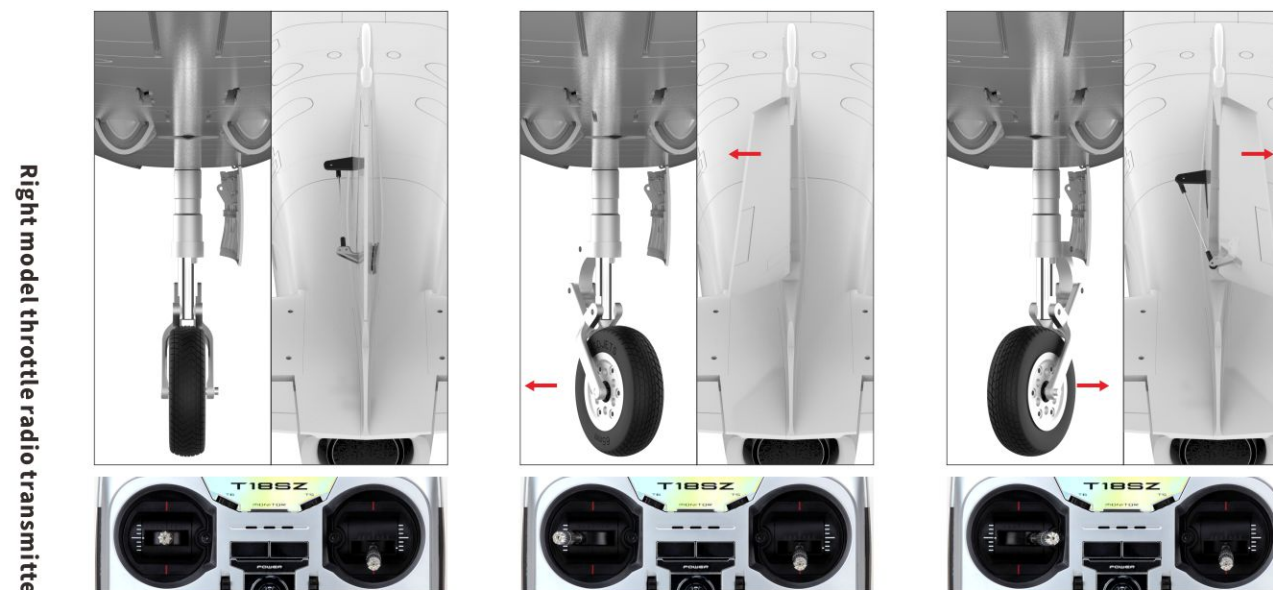

Note: If there is no special explanation, this user guide is introduced by default with the right model throttle radio transmitter as an example.

## First test and adjustment after assembly

### Possible direction reverse action

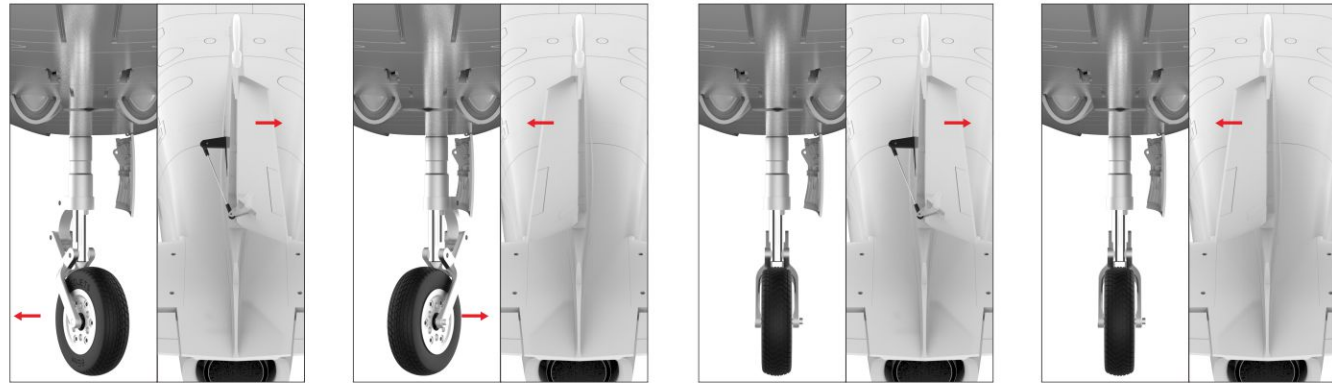

When the direction action is opposite to the specified action, you can adjust it with the 2 ways as below:

- (1). To find the reverse setting menu of direction in the radio transmitter menu, and switch in the direction item to the forward direction.
- (2). Adjust directions of the direction servo through the Super integrated control box (for details, pls see the MFC-2085 multi-function flight controller system english menu introduction & quick entrance);

**11. Direction adjustment:** After the setting, the standard position of the rudder surface will be adjusted. The direction rudder surface should be in the same plane as the vertical tail. If there is a left or right deviation need to be adjusted to vertical center, it can be adjusted by physical adjustment or system adjustment;

- (1). Physical adjustment: by adjusting the length of the pull rod to change the rudder surface angle to keep it in the same plane as the wing;
- (2). System Adjustment: Adjust the neutral point of the servo through the Super integrated control box (for details, pls see the MFC-2085 multi-function flight controller system english menu introduction & quick entrance);

**It is recommended to adjust the radio transmitter travel to 70%, adjusting the EXP curve under the same amount of servo, it recommends to adjust to -30 % EXP value in the first time; Can adjust according to the personal operating habits.**

The front landing gear steering is adjusted with the direction of the rudder surface. If you need to adjust one of them alone, it can be completed by adjusting the neutral point of the servo through the Super integrated control box. (for details, pls see the MFC-2085 multi-function flight controller system english menu introduction & quick entrance);

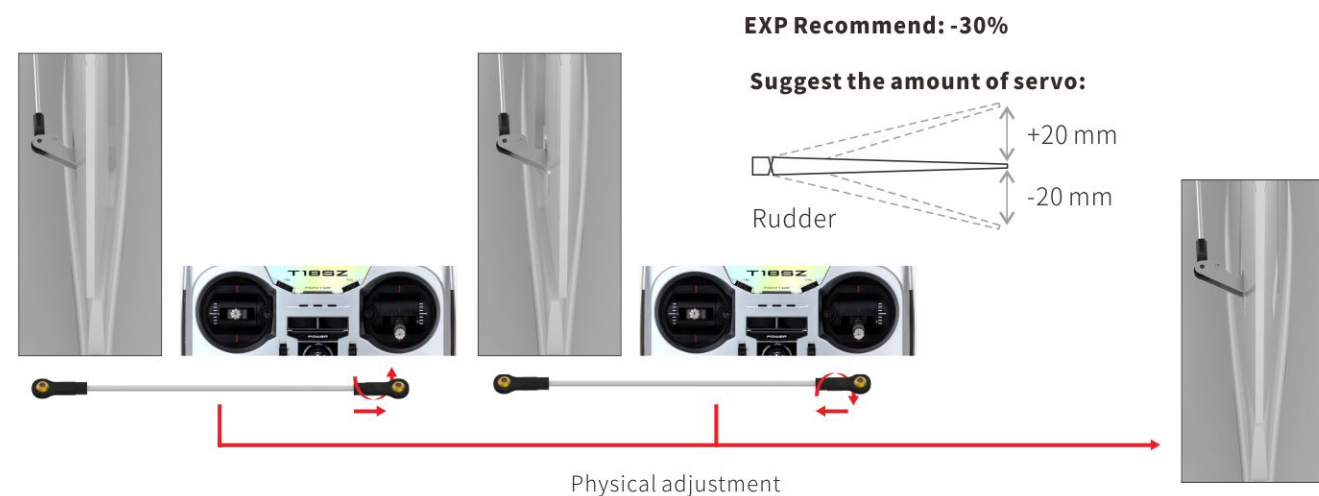

## First test and adjustment after assembly

**12. Flap test:** Check whether the flap action is correct

### Flap standard action

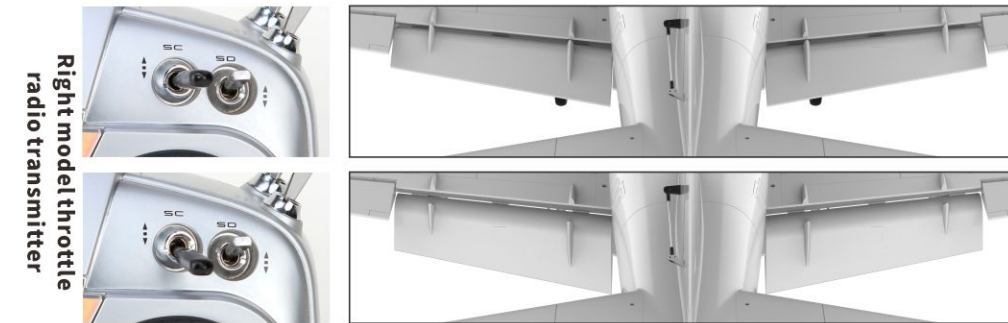

**Note:** If there is no special explanation, this user guide is introduced by default with the right model throttle radio transmitter as an example.

### Possible flap reverse action

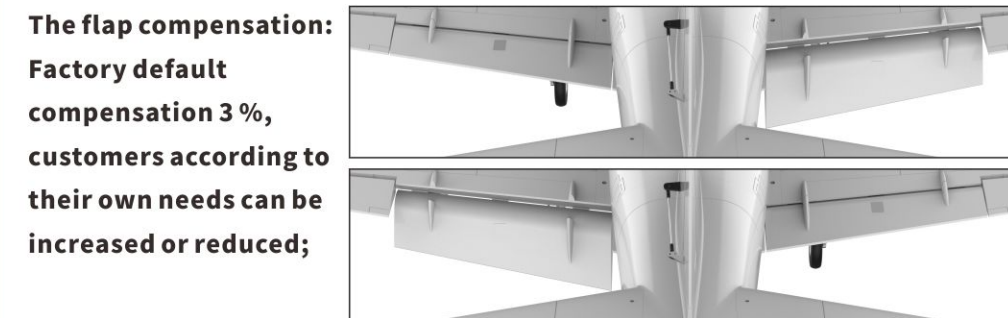

**The flap compensation:**  
**Factory default compensation 3%, customers according to their own needs can be increased or reduced;**

When the two flaps don't move in the same direction: adjust directions of the flap servo through the Super integrated control box (for details, pls see the MFC-2085 multi-function flight controller system english menu introduction & quick entrance);

**13. Flaps adjustment:** After the setting, start checking the flaps rudder surface, if the angles of the flaps rudder surface are consistent in first grade, and whether the angles of the flaps rudder surface are consistent in second grade. If the angles of the rudder surfaces on both sides are inconsistent, it can be adjusted by physical adjustment or system adjustment;

- (1). Physical adjustment: by adjusting the length of the pull rod to change the angle of the rudder surface to keep it at the same angle as the two rudder surfaces;
- (2). Through the Super integrated control box to adjust the wing steering gear stroke to solve (for details, pls see the MFC-2085 multi-function flight controller system english menu introduction & quick entrance); The radio transmitter is recommended to use the 100 % amount of servo, can adjust according to the personal operating habits.

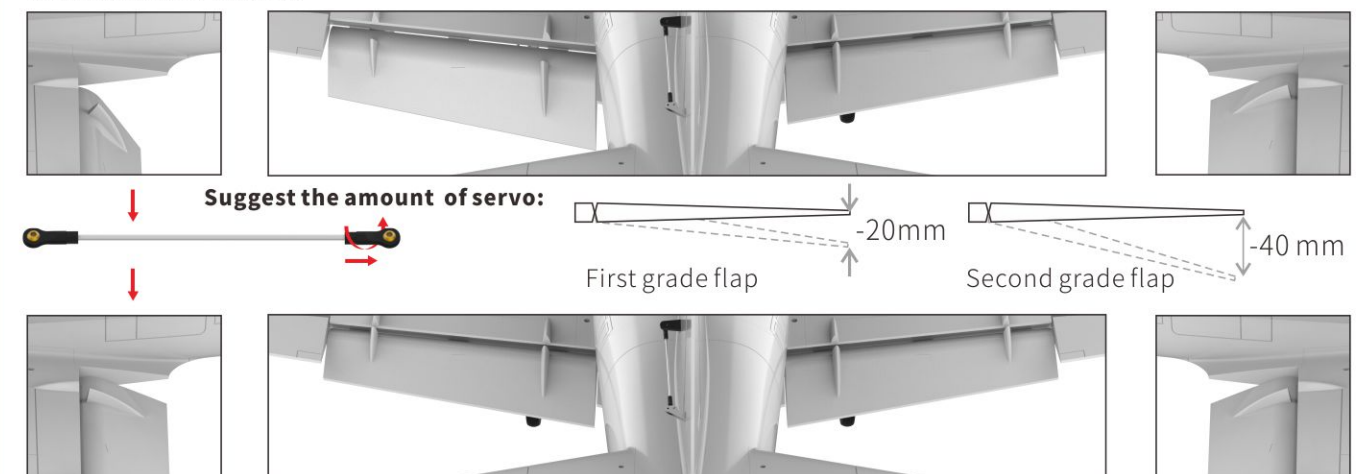



## First test and adjustment after assembly

### 14. Reduction plate test: Check whether the Reduction plate acts correctly



**Note:** If there is no special explanation, this user guide is introduced by default with the right model throttle radio transmitter as an example.

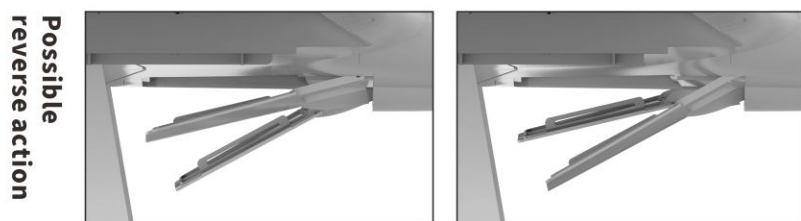

When the two Reduction plate don't move in the same direction: adjust directions of the flap servo through the Super integrated control box (for details, pls see the MFC-2085 multi-function flight controller system english menu introduction & quick entrance);

**15. Reduction plate adjustment:** After the setting, start checking the Reduction plate rudder surface, if the angles of the Reduction plate rudder surface are consistent in first grade, and whether the angles of the Reduction plate rudder surface are consistent in second grade. If the angles of the rudder surfaces on both sides are inconsistent, it can be adjusted by physical adjustment or system adjustment;

(1). Physical adjustment: by adjusting the length of the pull rod to change the angle of the rudder surface to keep it at the same angle as the two rudder surfaces;

(2). Through the Super integrated control box to adjust the wing steering gear stroke to solve (for details, pls see the MFC-2085 multi-function flight controller system english menu introduction & quick entrance); The radio transmitter is recommended to use the 100 % amount of servo, can adjust according to the personal operating habits.

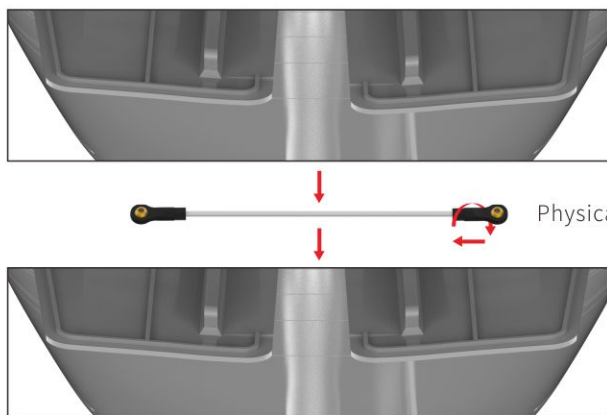

**Suggest the amount of servo:**

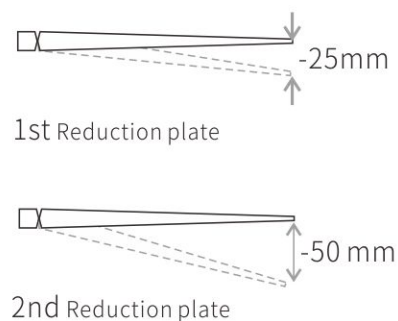

## First test and adjustment after assembly

### 16. Landing gear test and adjustment:

#### Standard landing gear action

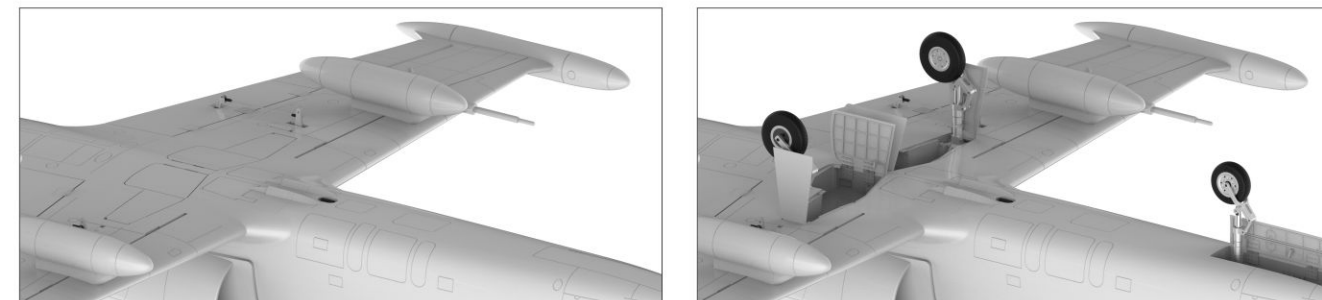

If the three are not synchronized, one up, two down or two up, one up and one down, it can also be solved by switching and inserting the positive and negative lines.(for details, pls see the MFC-2085 multi-function flight controller system english menu introduction & quick entrance);

MFC-2085 Super Integrated Control Box has a one-click retractable landing gear function (for details, pls see the MFC-2085 multi-function flight controller system english menu introduction & quick entrance);

#### Possible landing gear reverse action

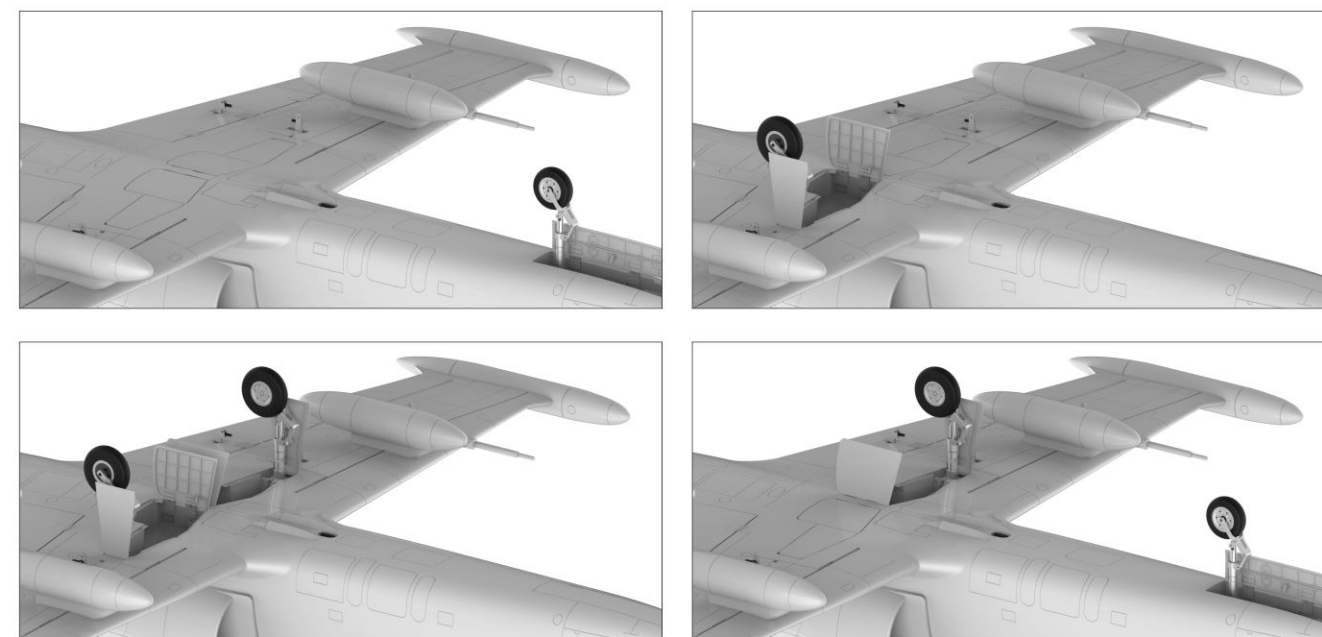

## First test and adjustment after assembly

**17. Ground test and adjustment:** After the above process is gradually completed, power the plane and do straight slide test to check whether the stroke volume of the front steering servo is full. If the steering is yaw or the steering angle is too large, it can be adjusted by physical adjustment or system adjustment:

(1).Steering yaw adjustment:

- ①. physical adjustment: Complete it by adjusting the length of the front wheel steering rod;
- ②. System Adjustment: Adjust the servo stroke by the Super Integrated Control Box(for details, pls see the MFC-2085 multi-function flight controller system english menu introduction & quick entrance);

(2).Excessive adjustment of steering angles:

- ①.Physical adjustment: adjust the install holes of the pull rod in the rocker arm of the steering servo of the front wheel;
- ②.System Adjustment: Adjust the servo stroke through the Super Integrated Control Box(for details, pls see the MFC-2085 multi-function flight controller system english menu introduction & quick entrance);

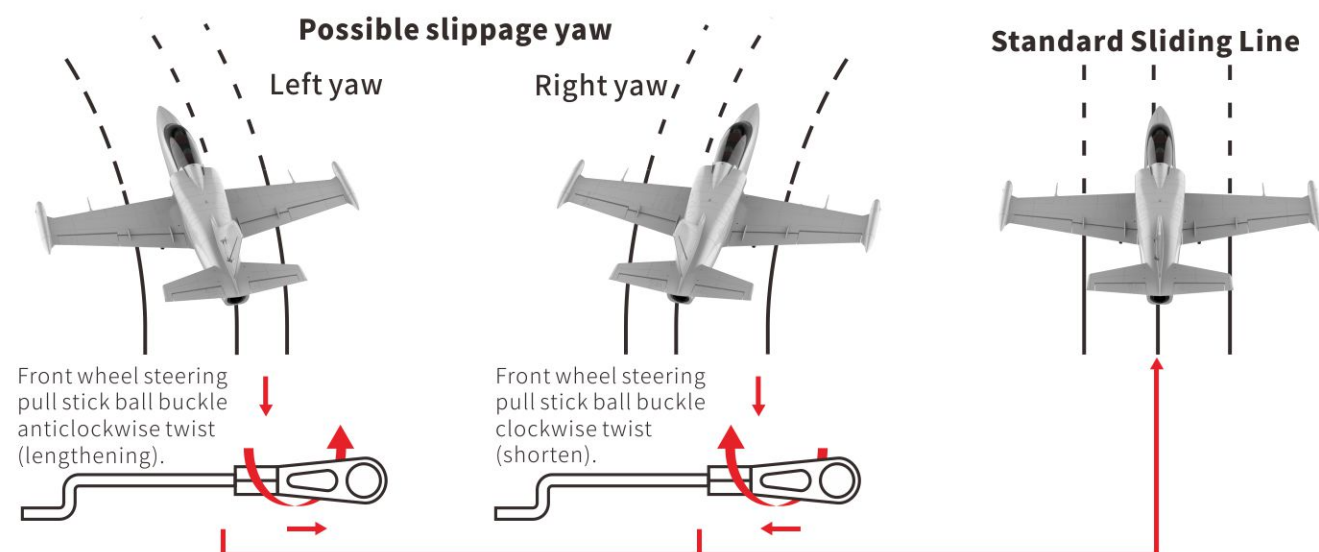

### The skid yaw angle over or smaller may happened during the operation

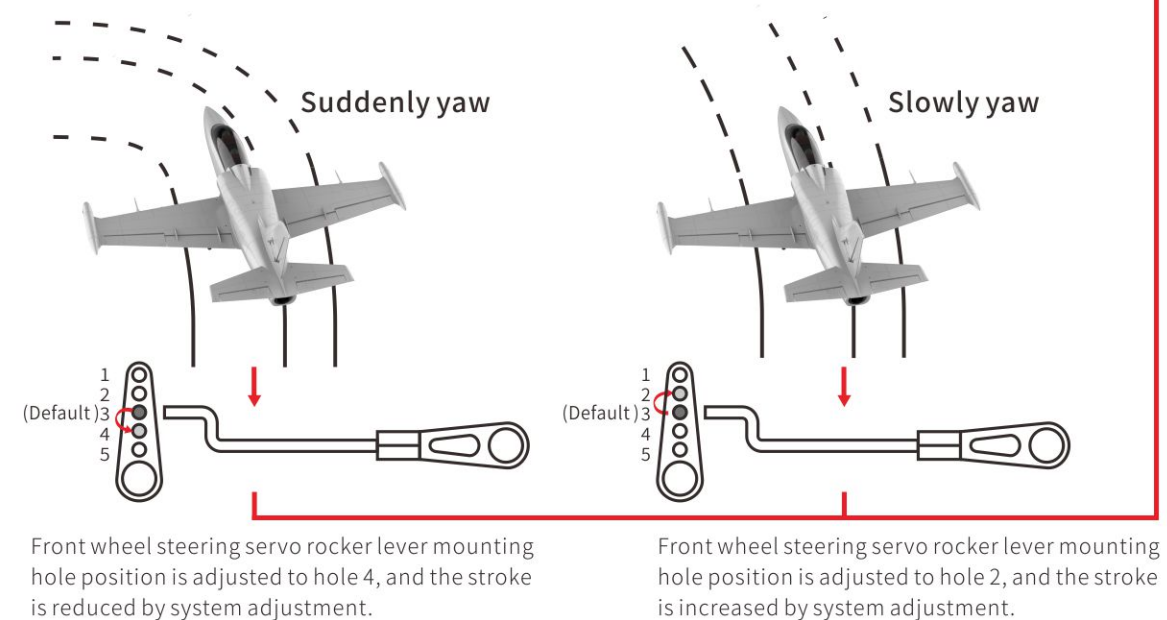

## First test and adjustment after assembly

### 18. Pre-takeoff center of gravity test:

Before the aircraft takes off, it is necessary to confirm whether the center of gravity of the aircraft is correct. The center of gravity of the Super snake is located behind the front edge of the main wing: 120~125mm.

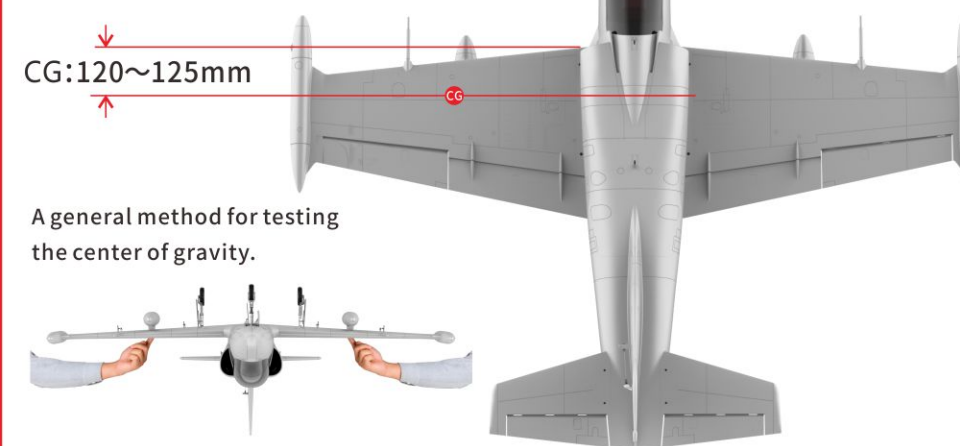

**19. Center of gravity adjustment:** If the center of gravity position is not correct, it must be adjusted. There are generally two situations:

A, the nose is overweight (the nose of the aircraft is drooping during the center of gravity testing on the ground), can move the battery back to the tail or replaced with a smaller capacity battery that within the scope of the aircraft's electricity demand;

B, the nose is too light (the nose of the aircraft is upwards during the center of gravity testing on the ground), move the battery forward to the nose or replaces the larger capacity battery that within the scope of the aircraft's electricity demand;

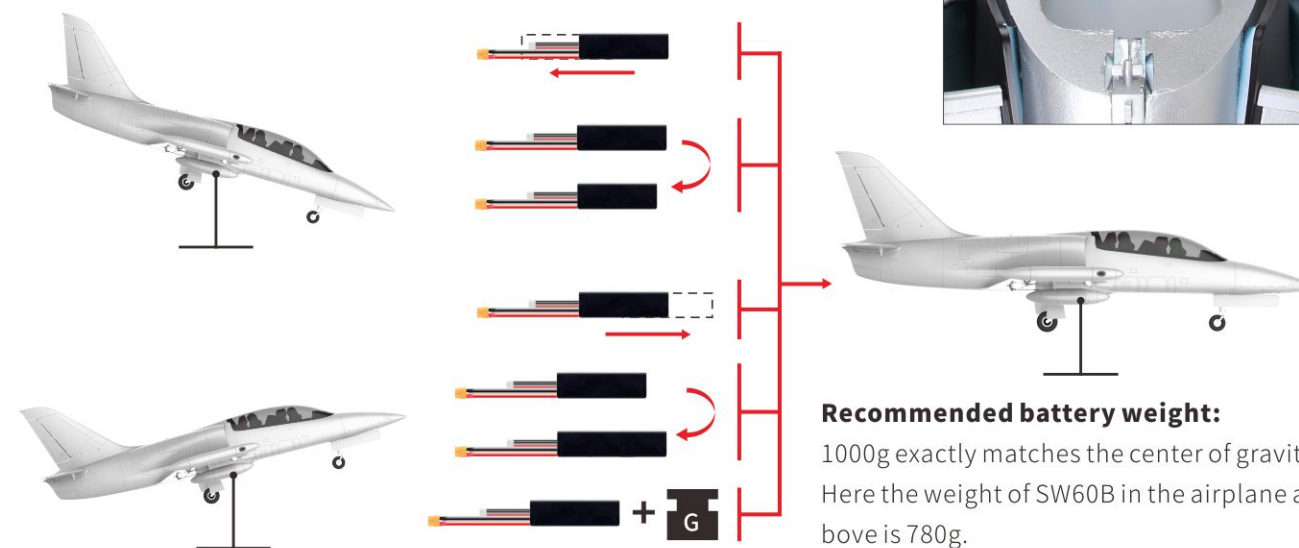

### Rear landing gear decomposition graph

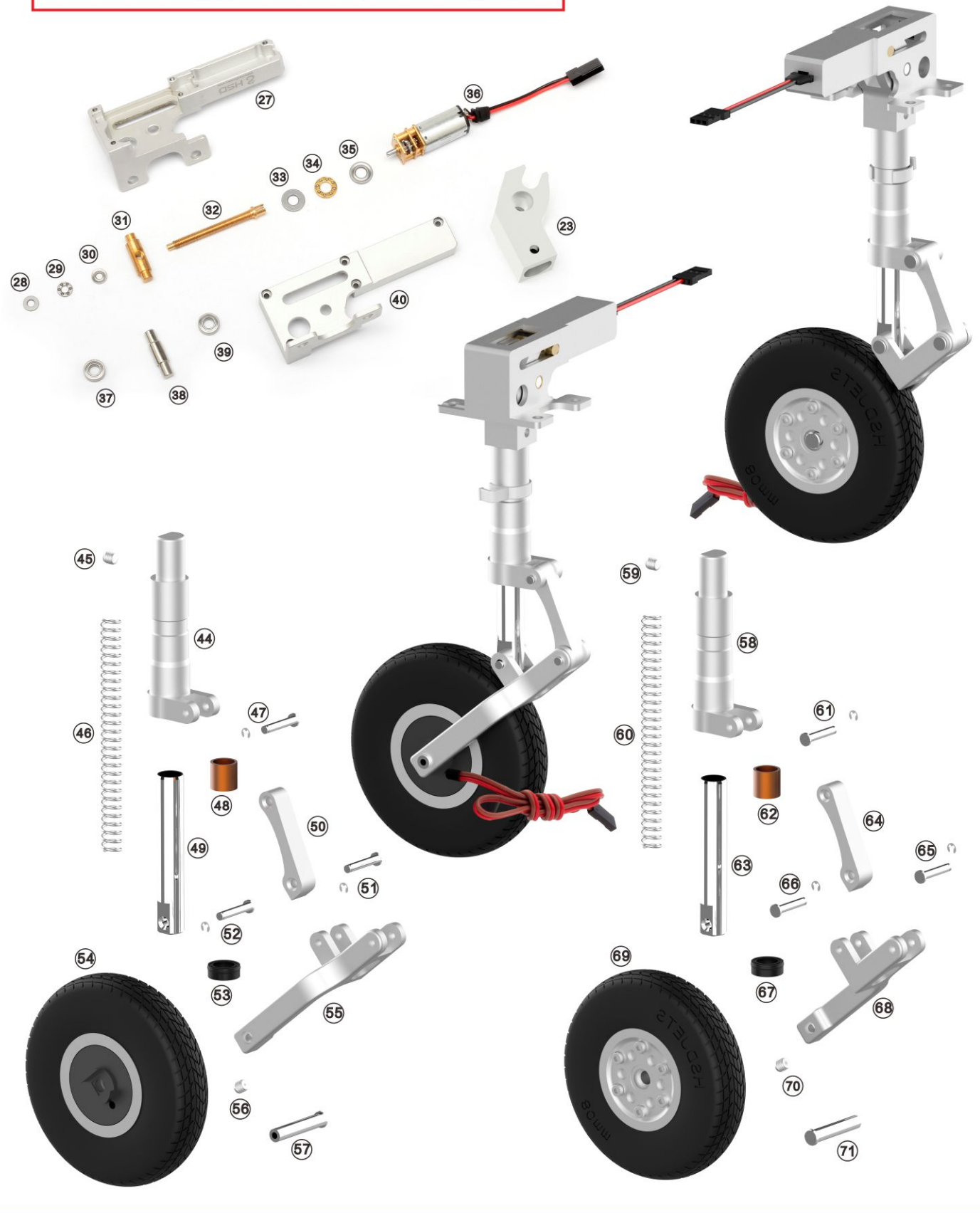

### Nose landing gear decomposition graph

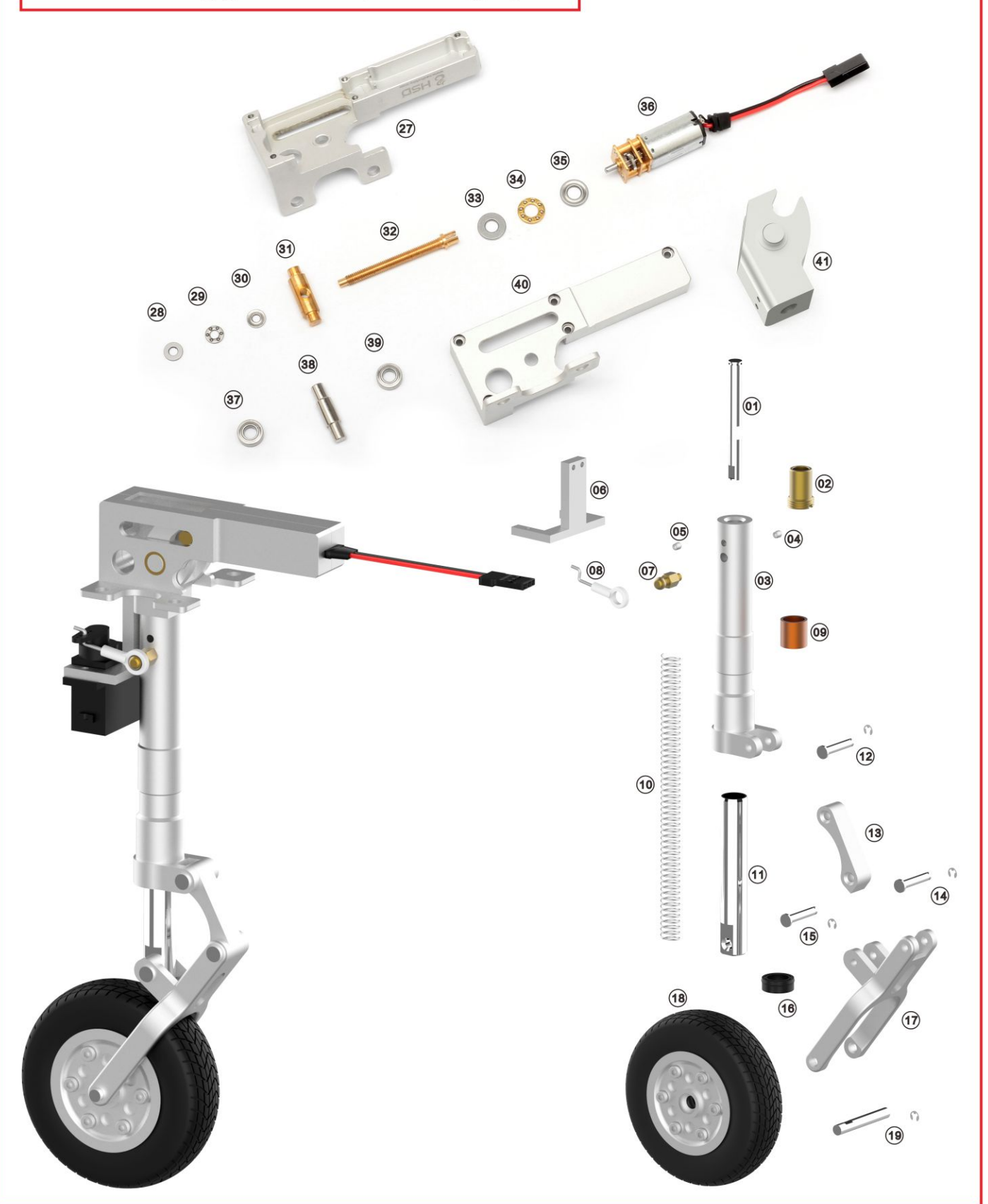

# HSDJETSUSA.com

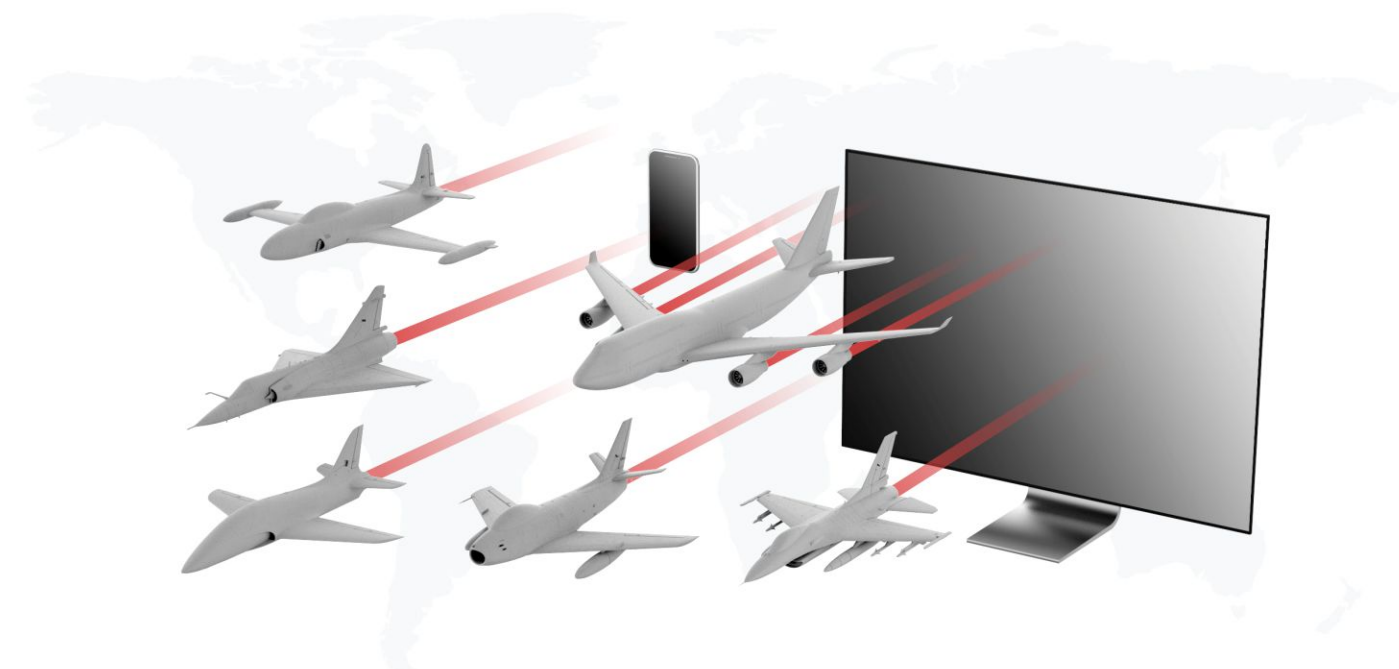

## Specification and configuration

### Specifications:

Wingspan	1665 mm / 65.6 in
Length	1916 mm / 75.4 in
Take off weight	10.5 kg / 23.1 lb (with 1800cc Aviation kerosene and 750cc smoke)
Cruising speed	100~140 km/h
Flying time	4~6 minutes
Main wing area	54 dm <sup>2</sup>
Loading of airfoil surface	195 g/dm <sup>2</sup>
Main material	20 times the import of aeromodelling EPO
Body Surface Treatment	Matte environmental water-borne paint + decal
Suitable experience level	<input type="checkbox"/> Zero basis <input type="checkbox"/> Beginner <input checked="" type="checkbox"/> Intermediate <input type="checkbox"/> Advanced
Pnp assembly difficulty	<input type="checkbox"/> ☆(10mins) <input type="checkbox"/> ★(20mins) <input checked="" type="checkbox"/> ★☆(30mins) <input type="checkbox"/> ★★(60mins) <input type="checkbox"/> ★★★(120mins)
Operate suitable for age	Above 18 years of age
Working temperature	0°C ~ 40°C

### Configuration:

Remote control channel	9CH (Selective configuration)
Control system	MFC-2085
Configuration of engine thrust	6kg~8kg
Power battery	According to engine matching (Selective configuration)
Receiver battery	2S / 7.4V / 5200 mAh Li-Po × 2 PCS (Selective configuration)
Servo	7.4V, 12g × 6 PCS / 7.4V, 25g × 7 PCS (Metal gear digital)
Landing gear	All-metal simulation electronic retractable landing gear
Electromagnetic brake	Yes
LED Lighting System	Yes
Aileron	Yes
Flaps	Yes
Horizontal tail	Yes
Vertical tail	Yes
Retarder plate	Yes
Smokeing system	Selective configuration
Reinforced gyro	Selective configuration
Packaging	Inner box + Outer Box (with marks)
Center of gravity	120~125 mm leading edge of main wing



扫码关注，谢谢支持！

www.hsdrc.com    www.hsdedf.com    www.hsdgo.com

sales1@hsdjetshuang sai.com

Company address : HSD Industry Park, Aigang Industry District, Huaide, Humen Town, Dongguan City, Guangdong Province, China (Post: 523926)

Production address : Building F6, Standardized Factory Buildings, Xixiu Industrial Park, Xixiu District, Anshun City, Guizhou Province, China (Post: 561099)