

HSDJETS[®]

HME-262

DOUBLE S-EDF 90MM

ASSEMBLY AND PRE-FLIGHT

INSTRUCTIONS

V1.0

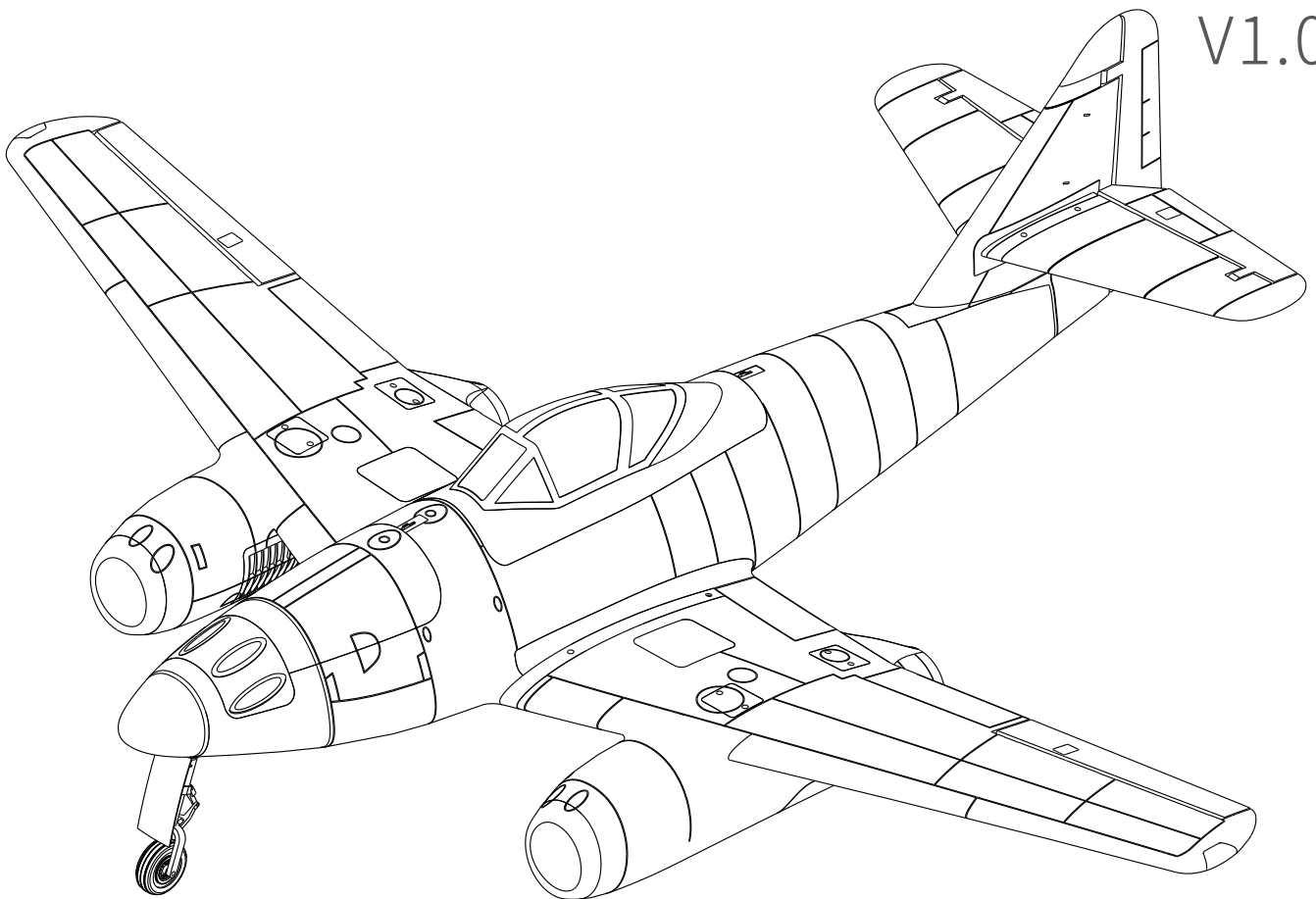

Product S/N:

Want to learn more about the product video,
pictures, and other matters of attention Please
log in: www.hsdr.com

INDEX

Introduction-----	03
Important Tips-----	03
Safety Flight Instructions-----	04
Description of each component-----	05
Install instructions1:Aircraft unpacking (PNP version)-----	06
Install instructions2:Install the nose cone and fuselage-----	07
Install instructions3:Install the left and right flat tails-----	07
Install instructions4:Install the vertical tail-----	08
Install instructions5:Install the wing power pack-----	08
Install instructions6:Install the main wing-----	09
First test and adjustment after assembly1-3: Boot process-----	09
First test and adjustment after assembly4-5: Boot process-----	10
First test and adjustment after assembly5:Aileron detection-----	10
First test and adjustment after assembly6:Aileron adjustment-----	11
First test and adjustment after assembly7:Elevator detection-----	11
First test and adjustment after assembly8:Elevating adjustment-----	12
First test and adjustment after assembly9:Direction detection-----	12
First test and adjustment after assembly10:Direction adjustment-----	13
First test and adjustment after assembly11:Flap detection-----	14
First test and adjustment after assembly12:Flaps adjustment-----	14
First test and adjustment after assembly13:Ground interview and adjustment-----	15
First test and adjustment after assembly14:Center of gravity detection before take-off-----	16
First test and adjustment after assembly15:Center of gravity adjustment-----	16
Landing gear assembly diagram-----	17
Specification and configuration-----	19

Introduction

Thank you so much for purchasing this plane, What you have now is the latest plane product of HSDJETS. This model has the following features:

01. Simulate the shape, reproduce the classic style of the real machine with rich details.
02. The whole machine is made of 35 times EPO and high-strength engineering plastics, with good crashworthiness.
03. HSDJETS has invested in the independent development of an exclusive MFC-2085-DR control system to fully integrate the landing gear, various channel servos, power, lighting and other systems to reduce complicated wiring.
04. The whole machine adopts 13 metal gear digital servos, including 4 pcs 12g high-speed servos and 9 pcs 25g hollow cup servos, which are solid and durable.
05. The integral main wing, with carbon fiber rods and glass fiber rib frame embedded in the main wing, can significantly improve the strength and torque resistance.
06. The main wing navigation light adopts the international standard of left red and right green, and there are many kinds of flashing modes, such as fast flashing, slow flashing and constant lighting, which makes flying in the night more realistic and charming.
07. The connecting plug of wing and fuselage, flat tail and vertical tail and fuselage adopts high-precision integrated forming plug, which is quick to assemble and reliable to connect.
08. Referring to the angle of the real machine, the front landing gear is designed with 105 degree simulation, and the rear landing gear adopts 11mm diameter landing gear legs which are directly locked in the electric slot, so that the landing gear legs can withstand the impact of stronger force and not easy to bend.
09. CNC machining metal high simulation hydraulic shock absorber landing gear, higher strength, better damping effect.
10. The wheel is equipped with bearing and electromagnetic brake system, which makes the rotation more smooth and the brake more sensitive.
11. Simulation of retractable landing gear cover plate.
12. All rudder angles are made of metal with high strength and zero virtual position.
13. All the standard screws are hexagon screws.
14. 3D EPO foam is used in the internal packaging to provide the safest protection for each part.

We believe the plane will give you an excellent flying experience. Before starting please read our manual.

Warning!



This is not a toy. Potentially dangerous for children under 14 years old. Children under 14 should not be permitted to operate the model without the supervision of an adult. Please keep these instructions for reference after model assembly.

Important Tips

1. Some experience necessary. Beginners should use under supervision;
2. Before install, please read through the instructions carefully and operate strictly under instructions;
3. HSDJETS and its distributors/dealers will not be held responsible or liable for injury due to incorrect assembly or wrongful use;
4. Not for use of 14 years or under;
5. Please do not use commercial cleaning products to clean plane. It will damage the painted EPO foam;
6. You should be careful to avoid flying in areas such as public places, high-voltage-intensive areas, near the highway, near the airport or any other place where laws and regulation clearly prohibit;
7. You can not fly in bad weather conditions such as thunderstorms, snow, and etc;
8. Do not store batteries within 2 meters of flammable or explosive materials;
9. Dispose of damaged batteries in a designated place;
10. In flying field, the waste after flying should be properly handled, it can't be abandoned or burned;
11. Before starting the airplane, ensure that the throttle is in low and the transmitter switch is on! Then connect the battery;
12. Do not try to take planes by hand when flying or slow landing process. You must wait for landing stop and when the blades stop turning, first disconnect the power supply and then carry it;
13. Whether flying or debugging on the ground, always ensure that there is no one in front of the aircraft.

Safty Flight Instructions

Strongly suggestion: users while enjoying the flying, please ensure that you are in a safe and reasonable environment.

1. It is better to try to choose an empty airspace, with no obstacles when you fly.
2. Stay away from people, animals, buildings, trees, water and other obstacles during flying.
3. Please keep the radio transmitter in your hand during the flight to control the model at any time to prevent accidents.
4. Please control the height of the aircraft to 120 meters to ensure the flight safety of the flyer and civil aviation. If you are in the area that have restrictions on flying altitude of 120 meters or less, please comply with its regulations. Make sure the model do not go out of sight and cause unnecessary accidents.

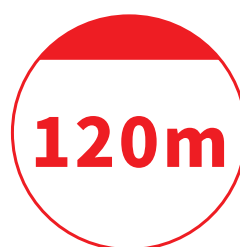
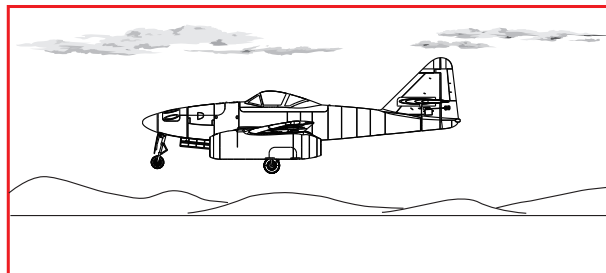

Flight environment requirements

1. Do not fly in areas such as transmission towers, communication base stations, high-voltage lines, or Wi-Fi hotspots to prevent the radio transmitter signal is interferenced.
2. Do not operate in bad weather, such as: strong winds(wind speed 10 m/s and above), raining, lightning, fog, snow, etc..
3. Flying is not recommended at altitudes above 4,500 meters and in the Arctic and Arctic circles.
4. Do not fly in airports or restricted areas under the relevant laws or regulations.

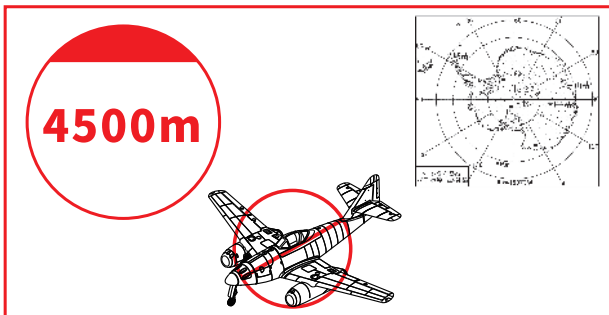
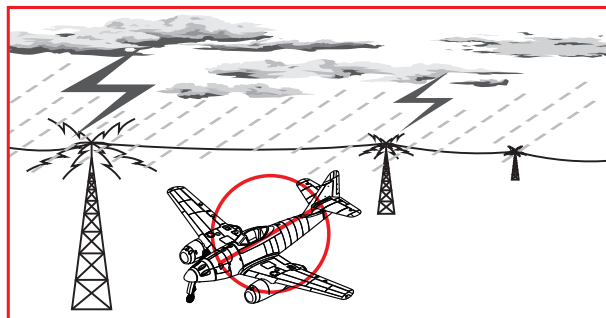
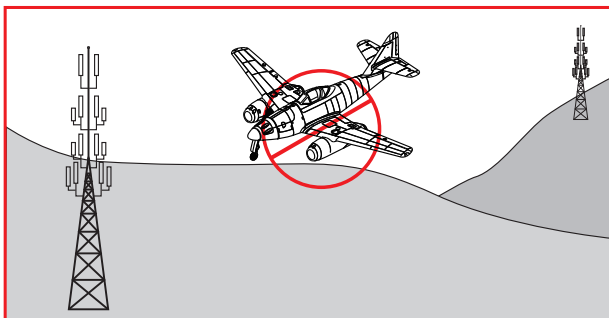

S-EDF 90mm HME-262

Description of each component

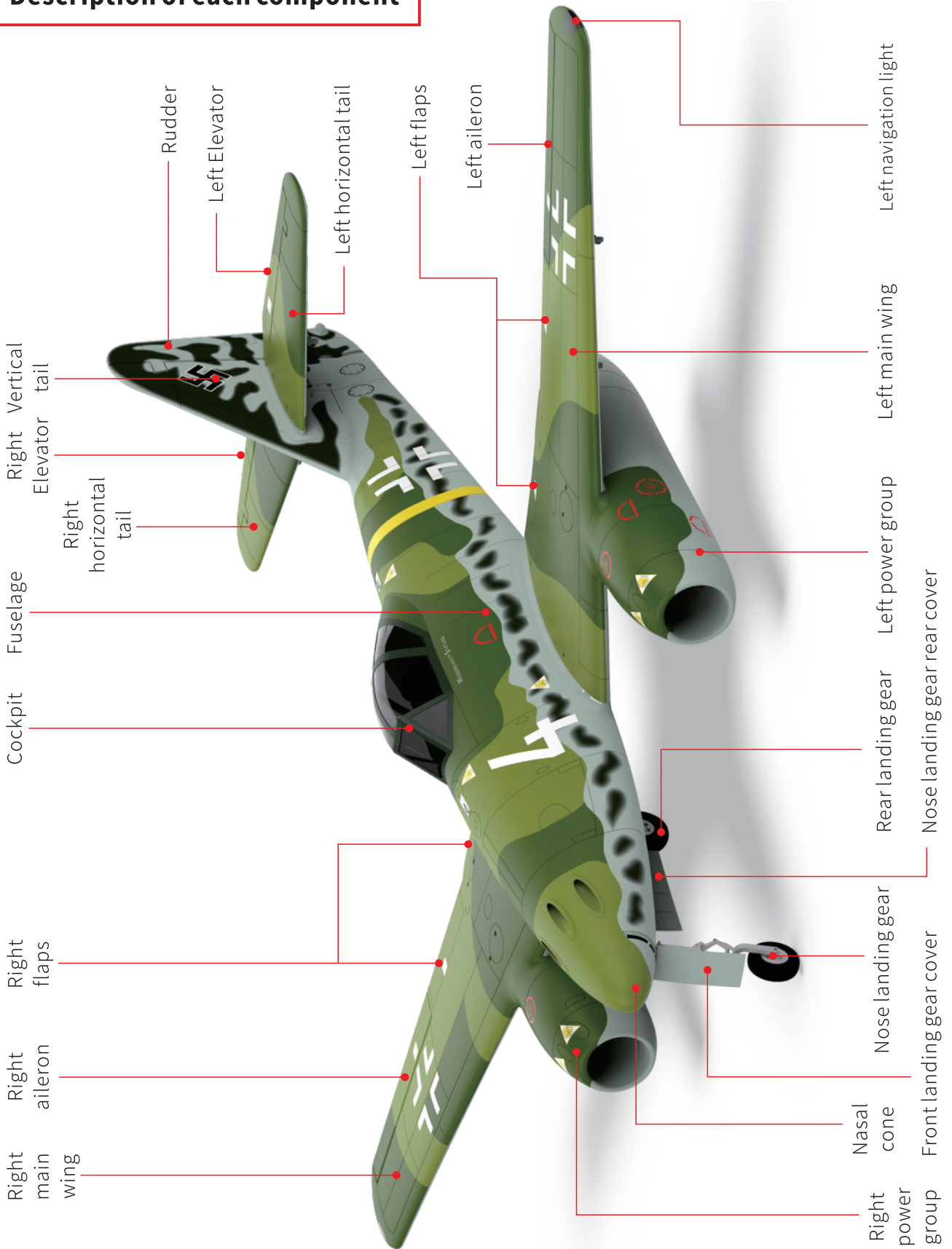

Install instructions

1. Aircraft unpacking (PNP version): Take out the fuselage, left and right main wings, nose cone, vertical tail, left and right power group, left and right horizontal tail, bolt rod, instruction manual, accessory package and other items in the carton, and check whether the quantity of packing articles is complete according to the packing list in the manual.

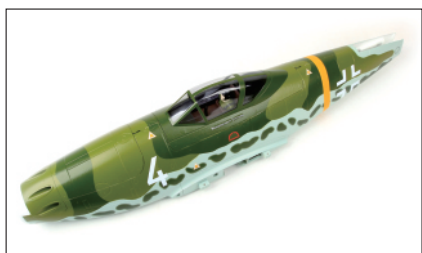

Fuselage×1



Left main wing×1



Right main wing×1



Nose cone×1



Vertical tail×1



Left power group×1



Left horizontal tail×1

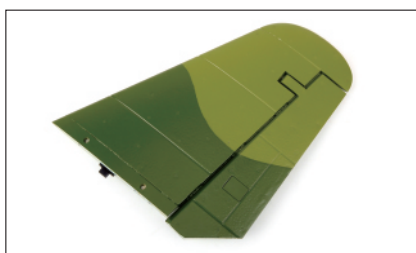

Right horizontal tail×1



Right power group×1

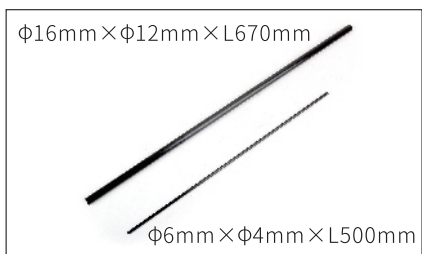

Bolt rod×1

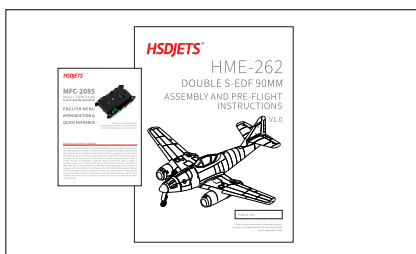

Manual×1



Accessory Package ×1

Install instructions

2. Installation of nose cone and fuselage: take out the nose cone and body from PE bag and place them on the flat and clean table. Apply EPO glue to the contact section of nose cone and fuselage respectively to fix them.



3. Install the left and right horizontal tail: firstly, pass the flat tail reinforcement bar ($\phi 6\text{mm} \times \phi 4\text{mm} \times L500\text{mm}$) through the designated hole position of the vertical tail, ensure that the extension length of the horizontal tail reinforcement rod at the left and right ends is equal, and then align the hole positions of the left and right horizontal tail with the reinforcing rod respectively, and insert the reinforcing rod. Before fully inserting, make sure that the signal line between the vertical tail end and the flat tail end is connected, and then screw (HM) is used after the left and right flat tail are installed in place ($3 \times 10\text{mm} \times 4\text{PCS}$).

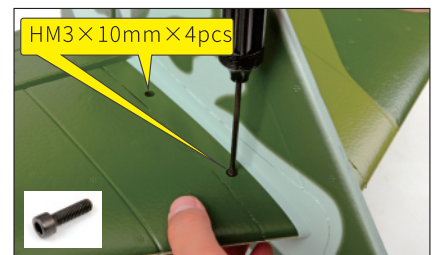
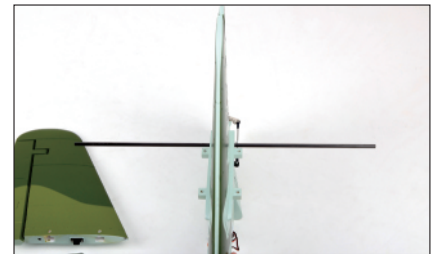
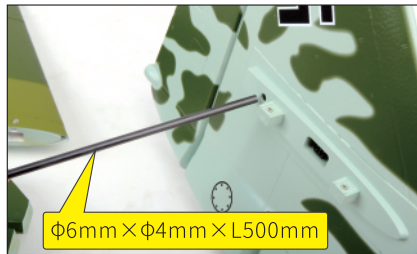

Install instructions

4. Install the vertical tail: First install the vertical tail at the designated position of the fuselage, and ensure that the signal wiring between the vertical tail end and the fuselage end is well connected; after installation in place, fix the bottom with screws (HM3 × 10mm × 2pcs). (Note: the color of the wire must be inserted well to the color of the wire, and the wire should not be inserted reversely.)

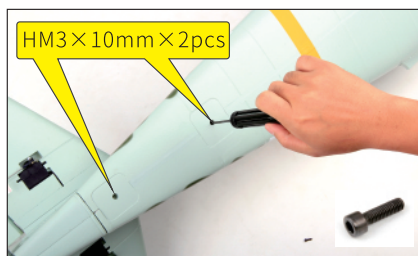
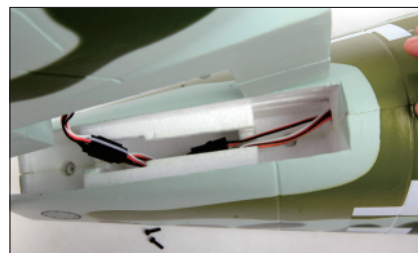
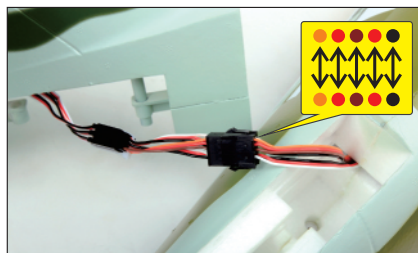

5. Install the wing power pack: Remove the wire baffle of the wing and install the power pack at the designated position of the wing to ensure that the wire rod of the power pack is not pressed onto the wing. After the power pack is installed in place, fix it with screws (HA3 × 10mm × 4pcs). Connect the power line and throttle signal line respectively, and then install the wire baffle. (Note: the color of the wire must be inserted well to the color of the wire, and the wire should not be inserted reversely.)

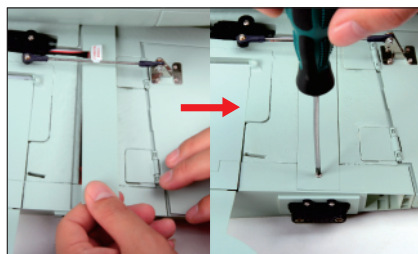
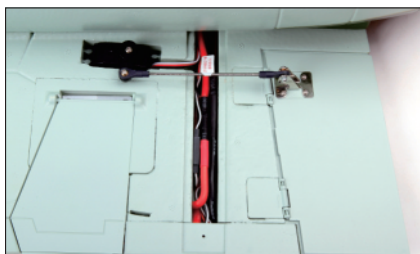
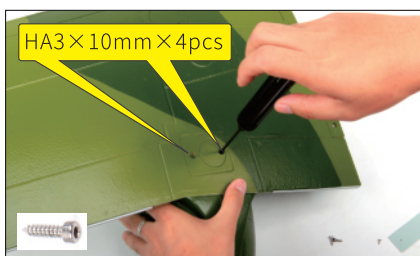
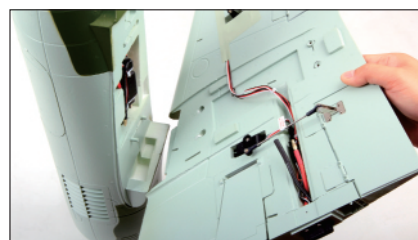
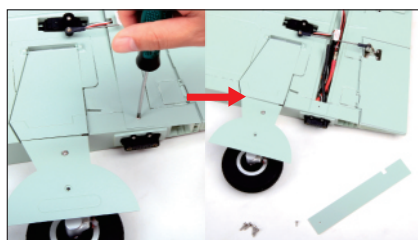

S-EDF 90mm HME-262

First test and adjustment after assembly

6. Install the main wing: Pass the main wing reinforcement rod ($\phi 16\text{mm} \times \phi 12\text{mm} \times L670\text{mm}$) through the designated hole position of the fuselage, ensure that the extension length of the main wing reinforcement bar at the left and right ends of the fuselage is equal, and then align the hole position of the left and right main wing with the main wing reinforcement rod, and insert the reinforcing rod. Before fully inserting, make sure that the signal line between the main wing end and the fuselage end is connected, and then fix it with screws (HM3 $\times 10\text{mm} \times 4\text{pcs}$) after installation) The assembly of me262 was completed.

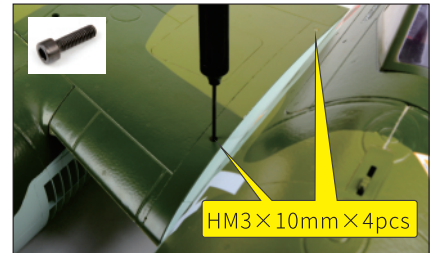
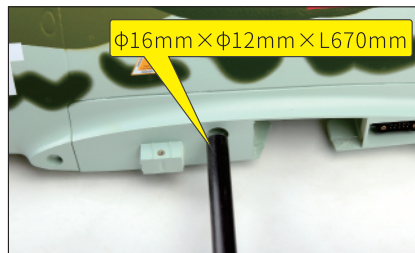

First test and adjustment after assembly

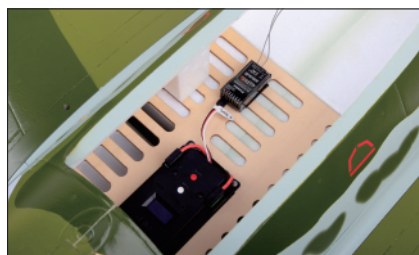

1. Locate the S-BUS line in the MFC-2085 integrated control box and connect it to the S-BUS port of the receiver.



2. Turn on the remote control.



3. Connect the MFC-2085 integrated control box to a set of 2S lithium batteries.

(Note: If the receiver does not support S-BUS, the MFC-2065 integrated control box needs to be connected to the PWM signal line;)

First test and adjustment after assembly



4. MFC-2085 integrated control box S-BUS mode channel setting, the factory channel is: S-BUS Setting.

5. Check the Super Integrated Control Box S-BUS mode channel settings. The factory default channel is: S-BUS Setting

(Note: You can change the default gear switch position according to your own custom channel.)

- | | |
|-----------------------------------|-------------------------------------|
| 1. AUX1 CH Aileron (default CH1) | 7. AUX7 CH Spare (default CH7) |
| 2. AUX2 CH Elevator (default CH2) | 8. AUX8 CH Spare |
| 3. AUX3 CH Rudder (default CH4) | 9. A/B LIGHT CH Spare (default CH3) |
| 4. AUX4 CH Flap (default CH6) | 10. REDUCTION PLATE CH |
| 5. AUX5 CH Spare | 11. WHEEL BRAKE CH (default CH8) |
| 6. AUX6 CH Throttle (default CH3) | 12. LANDING GEAR CH (default CH5) |

5. Aileron detection: check whether the aileron movement is correct

Right model throttle radio transmitter

Aileron standard action



Note: If there is no special instruction, this user guide uses the right-hand oil remote control as an example for introduction.

When the aileron action is opposite to the specified action, you can find the servo reverse setting menu in the remote-control menu, and switch forward and reverse in the aileron item bar.

Right model throttle radio transmitter

Possible ailerons reverse action



First test and adjustment after assembly

6. Aileron adjustment: After completing the setting, start to adjust the standard position of the rudder surface. The aileron rudder surface should be on the same plane as the wing. If there is upturn or downturn that needs to be leveled, it can be adjusted through physical adjustment or system adjustment;

(1). Physical adjustment: change the length of the rudder surface by adjusting the length of the lever to keep it on the same plane with the wing;

(2). System adjustment: Adjust the neutral point of the servo through the Super integrated control box (for details, pls see the MFC-2085 multi-function flight controller system english menu introduction & quick entrance);

It is recommended to use 80% rudder amount for remote control, adjust the EXP curve under the premise of the same rudder amount, firstly, it is recommended to modulate -30% EXP value; actually adjust according to personal operating habits.



Suggest the amount of servo:

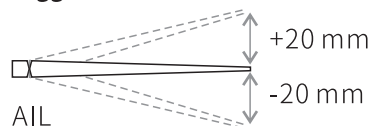

EXP suggest: -30%

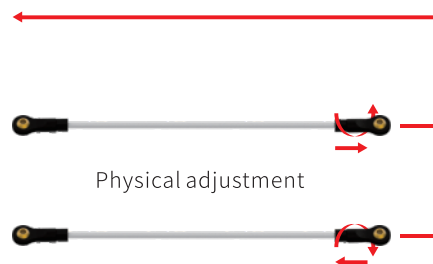

7. Elevator detection: check whether the lifting action is correct

Right model throttle radio transmitter



Aileron standard action



Possible ailerons reverse action



Note: If there is no special instruction, this user guide uses the right-hand oil remote control as an example for introduction.

When the elevator action is opposite to the specified action, you can find the servo reverse setting menu in the remote-control menu, and switch forward and reverse in the elevator item bar.

First test and adjustment after assembly

8. Elevating adjustment: After completing the setting, start to adjust the standard position of the rudder surface. The elevator surface should be on the same plane as the horizontal tail. If there is upturn or downturn that needs to be leveled, it can be adjusted through physical adjustment or system adjustment;

(1) Physics Adjustment: change the length of the rudder surface by adjusting the length of the lever to keep it on the same plane as the wing;

(2) System adjustment: Adjust the neutral point of the servo through the Super integrated control box (for details, pls see the MFC-2085 multi-function flight controller system english menu introduction & quick entrance);

It is recommended to use 70% rudder amount for remote control, and the rudder amount does not change. Adjust the EXP curve under the premise, the first suggestion is to modulate the -30% EXP value; the actual adjustment should be based on personal operating habits.

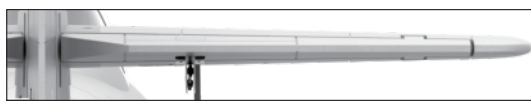

Suggest the amount of servo:

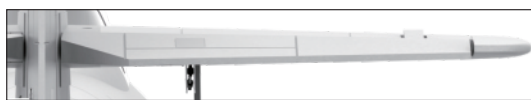
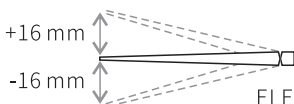

Physical adjustment

EXP suggest: -30%



9. Direction detection: check whether the direction is correct

Rudder standard action

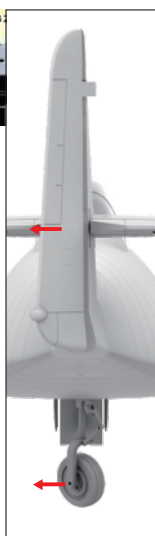

Note: If there is no special instruction, this user guide uses the right-hand oil remote control as an example for introduction.

First test and adjustment after assembly

Possible rudder reverse action

When the rudder action is opposite to the specified action, you can find the servo reverse setting menu in the remote-control menu, and switch forward and reverse in the rudder item bar.

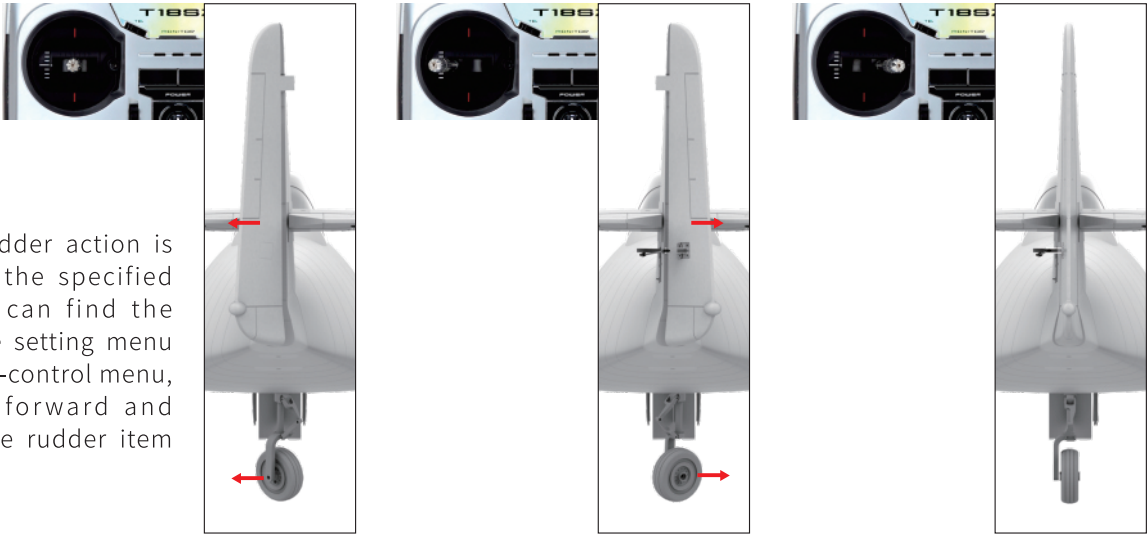

10.Direction adjustment: After completing the setting, start to adjust the standard position of the rudder surface. The rudder surface should be in the same plane as the vertical tail. If there is a left or right deviation, it needs to be adjusted to the vertical center, which can be adjusted through physical adjustment or system adjustment:

(1).Physical adjustment: change the length of the rudder surface by adjusting the length of the lever to keep it on the same plane with the wing;

2).System adjustment: Adjust the neutral point of the servo through the Super integrated control box (for details, pls see the MFC-2085 multi-function flight controller system english menu introduction & quick entrance);

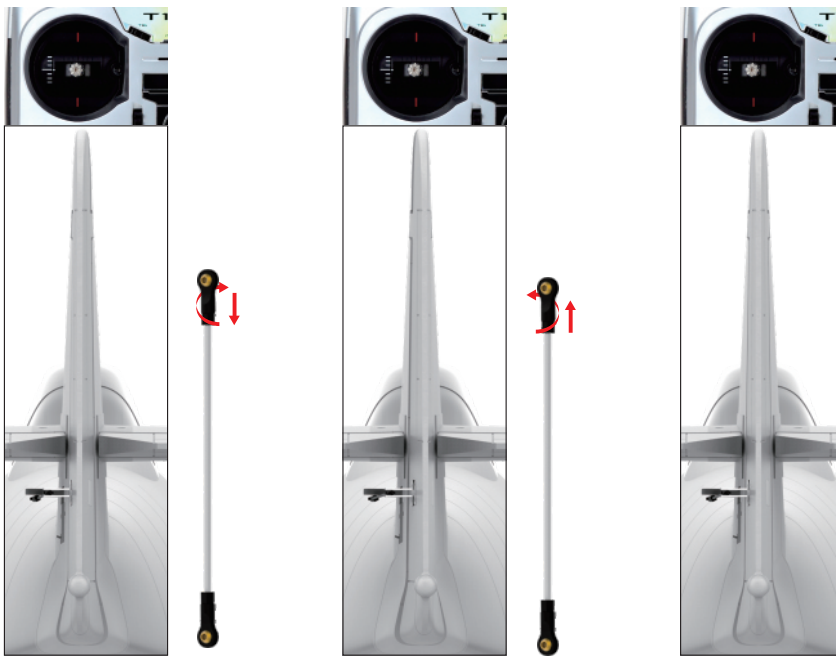

Physical adjustment

It is recommended to use 80% rudder for remote control, and it should be adjusted according to personal habits;

Suggest the amount of servo:

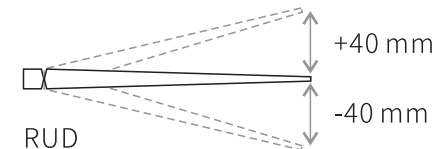

EXP suggest: -30%

First test and adjustment after assembly

11. Flap detection: check whether the flaps are correct

Right model throttle
radio transmitter



Flaps standard action

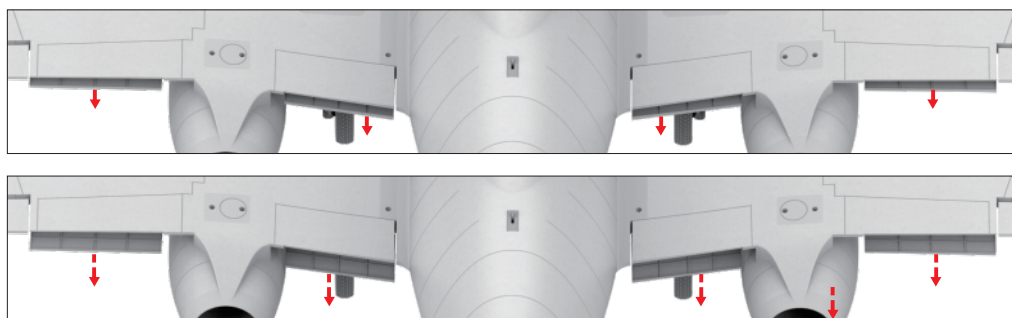

12. Flaps adjustment: After finishing the setting, start to check the flap rudder surface, whether the first gear flap rudder surface is the same in length, whether the second gear flap rudder surface is the same, if the two sides of the rudder surface are inconsistent, you can pass Physical adjustment; Physical adjustment: Change the length of the rudder surface by adjusting the length of the lever to keep it at the same degree with the two rudder surfaces. It is recommended to use 100% rudder for remote control, but it should be adjusted according to personal operating habits.

It is suggested to use 100% rudder for remote control, which should be adjusted according to personal operating habits.

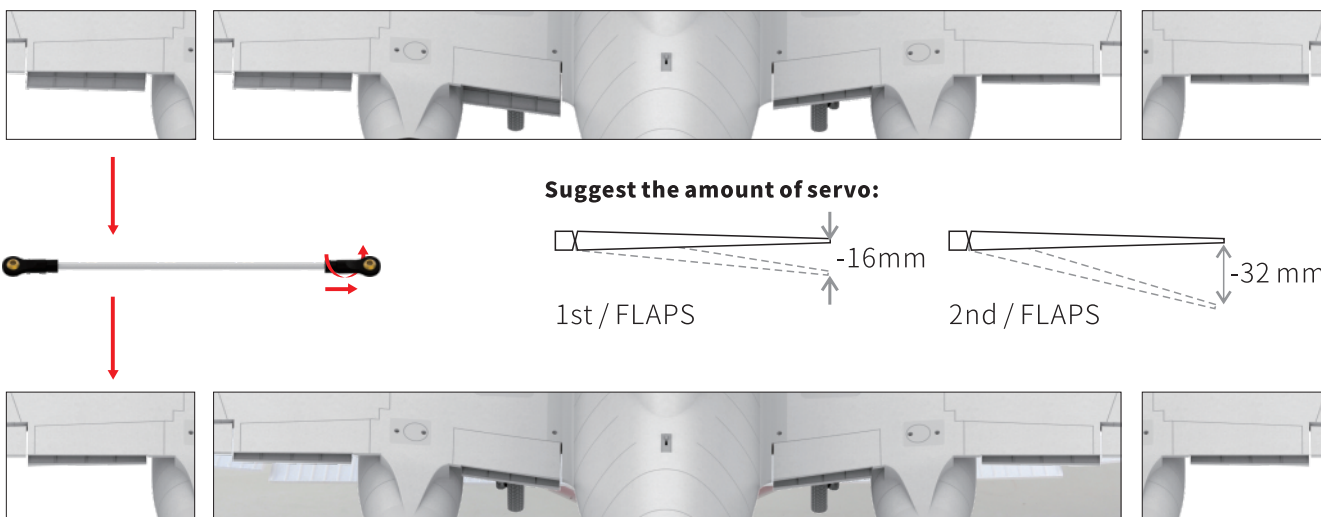

First test and adjustment after assembly

13. Ground test and adjustment: After the above process is gradually completed, power the plane and do straight slide test to check whether the stroke volume of the front steering servo is full. If the steering is yaw or the steering angle is too large, it can be adjusted by physical adjustment or system adjustment:

(1).Steering yaw adjustment:

- ①. physical adjustment: Complete it by adjusting the length of the front wheel steering rod;
- ②. System Adjustment: Adjust the servo stroke by the Super Integrated Control Box(for details, pls see the MFC-2085 multi-function flight controller system english menu introduction & quick entrance);

(2).Excessive adjustment of steering angles:

- ①.Physical adjustment: adjust the install holes of the pull rod in the rocker arm of the steering servo of the front wheel;
- ②.System Adjustment: Adjust the servo stroke through the Super Integrated Control Box(for details, pls see the MFC-2085 multi-function flight controller system english menu introduction & quick entrance);

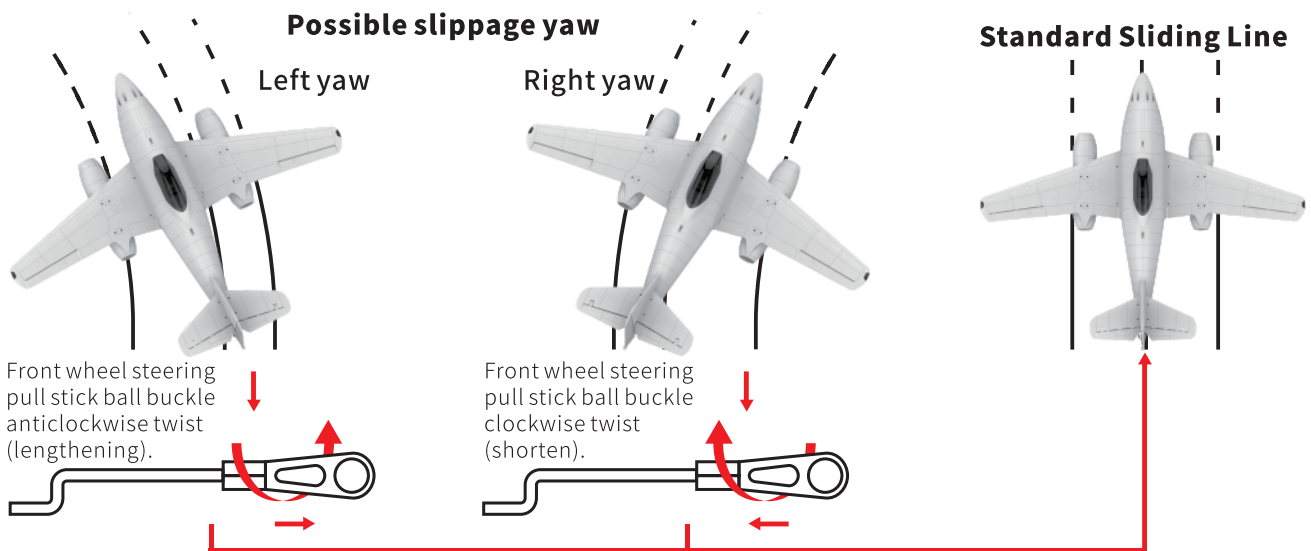

The skid yaw angle over or smaller may happened during the operation

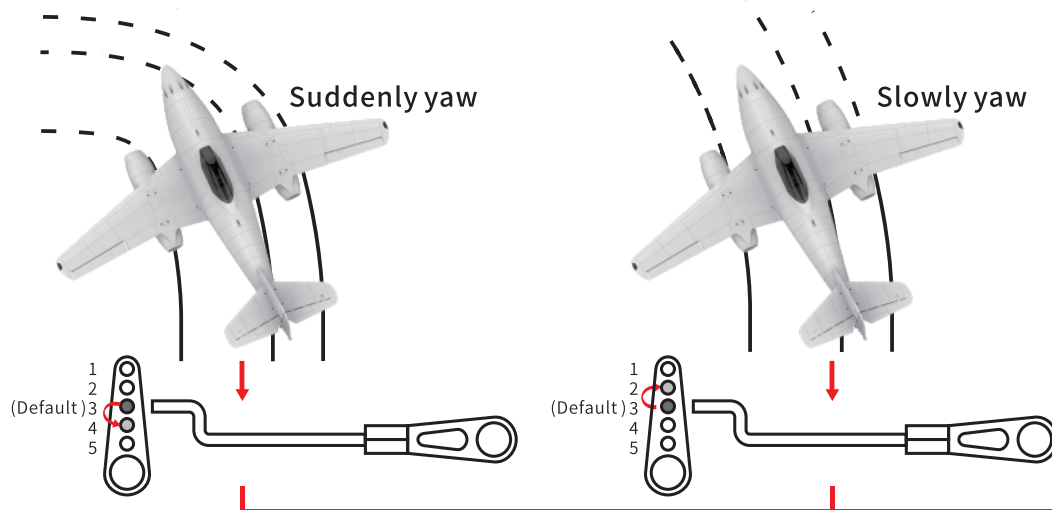

Front wheel steering servo rocker lever mounting hole position is adjusted to hole 4, and the stroke is reduced by system adjustment.

Front wheel steering servo rocker lever mounting hole position is adjusted to hole 2, and the stroke is increased by system adjustment.

First test and adjustment after assembly

14.Center of gravity detection before take-off:

Before starting the machine, you need to confirm whether the position of the center of gravity of the machine is correct. The center of gravity is located behind the front edge of the main wing: 145~150mm.



A general method for measuring the center of gravity

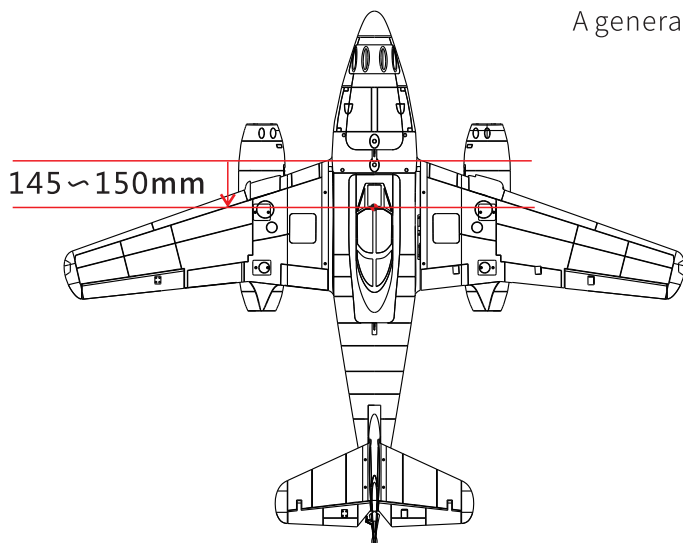

Battery assembly diagram

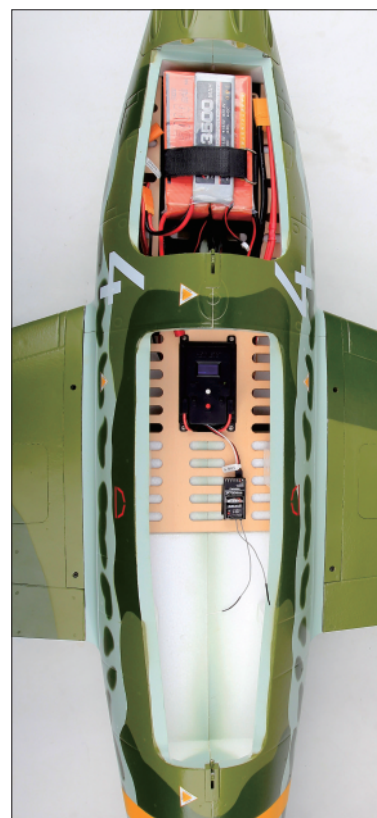

15.Center of gravity adjustment: If the position of the center of gravity is wrong, it must be adjusted. Generally, there are two situations:

A.If the nose is too heavy (lower your head during ground center of gravity test), you can move the battery back to the rear of the aircraft or replace with a smaller capacity battery that can meet the power requirements of the aircraft;

B.The machine head is too light (head up during the ground center of gravity test), move the battery forward to the machine head or increase the counterweight or replace with a larger capacity battery that can meet the power requirements of the machine.

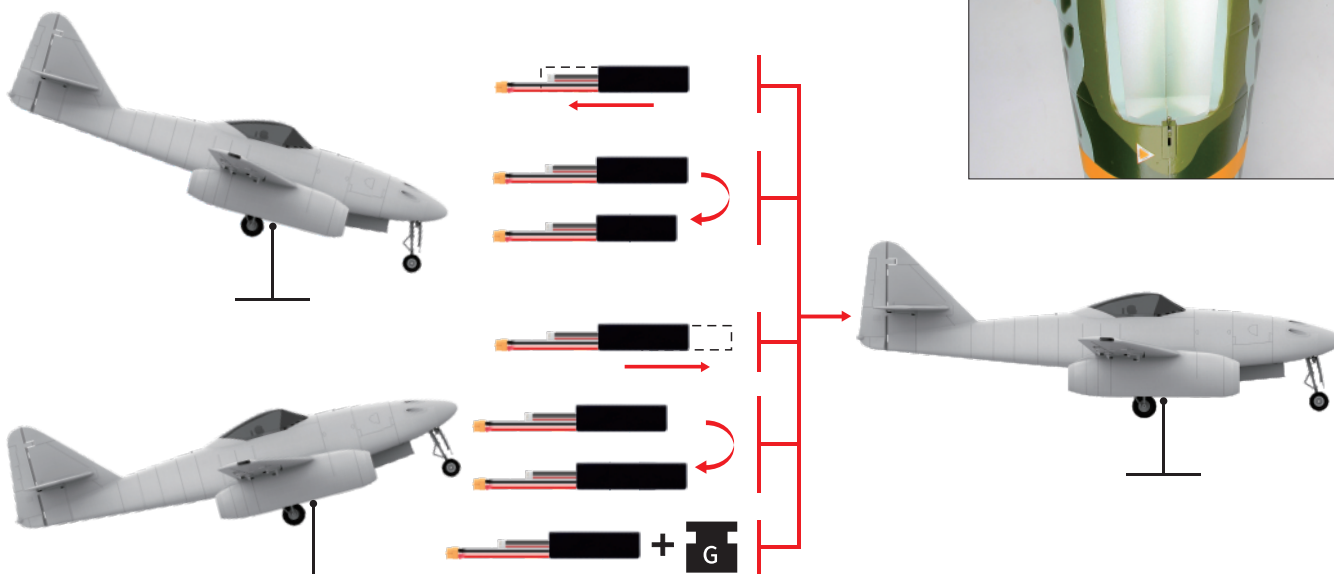

S-EDF 90mm HME-262

Front landing gear assembly diagram

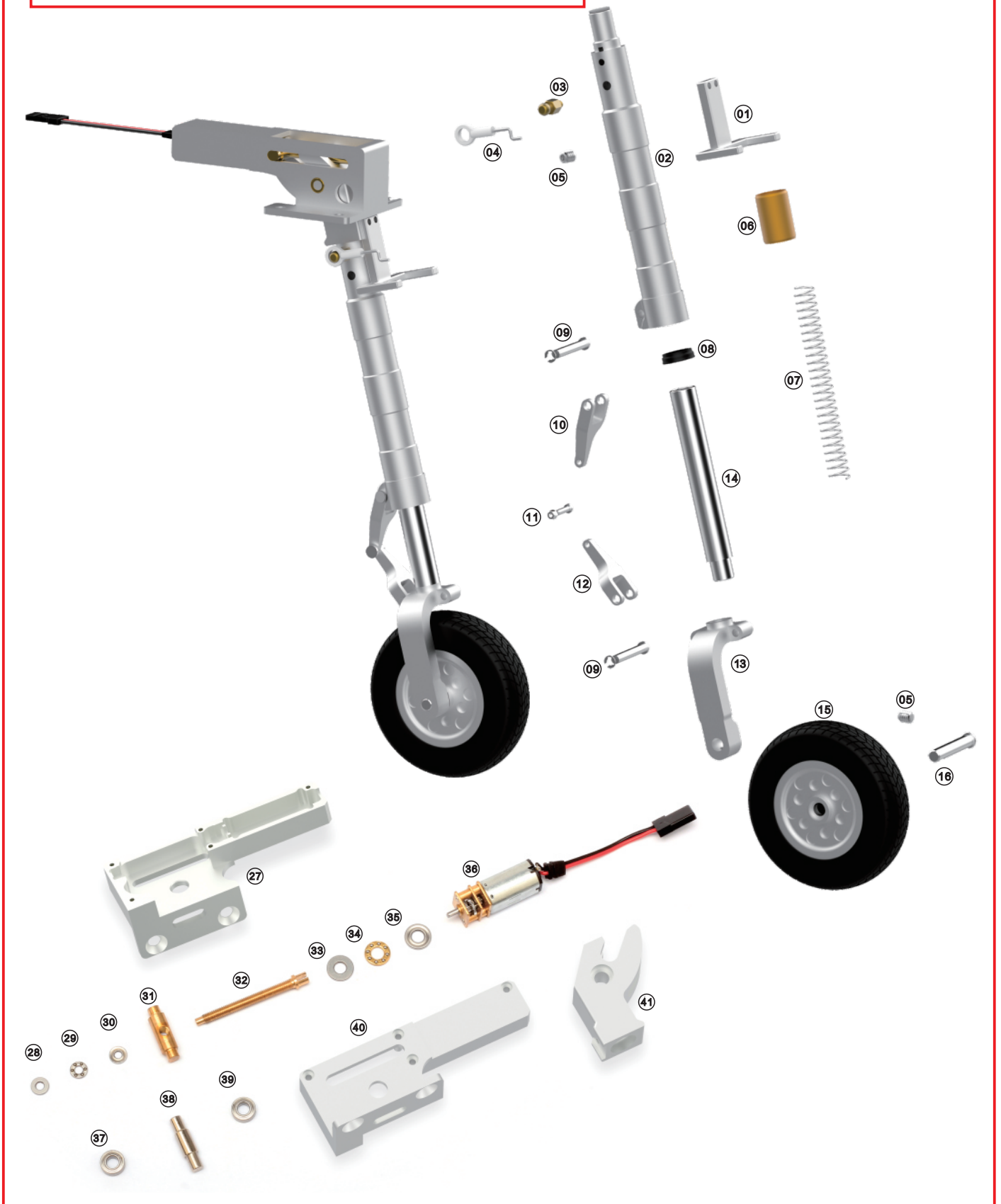

Rear landing gear assembly diagram

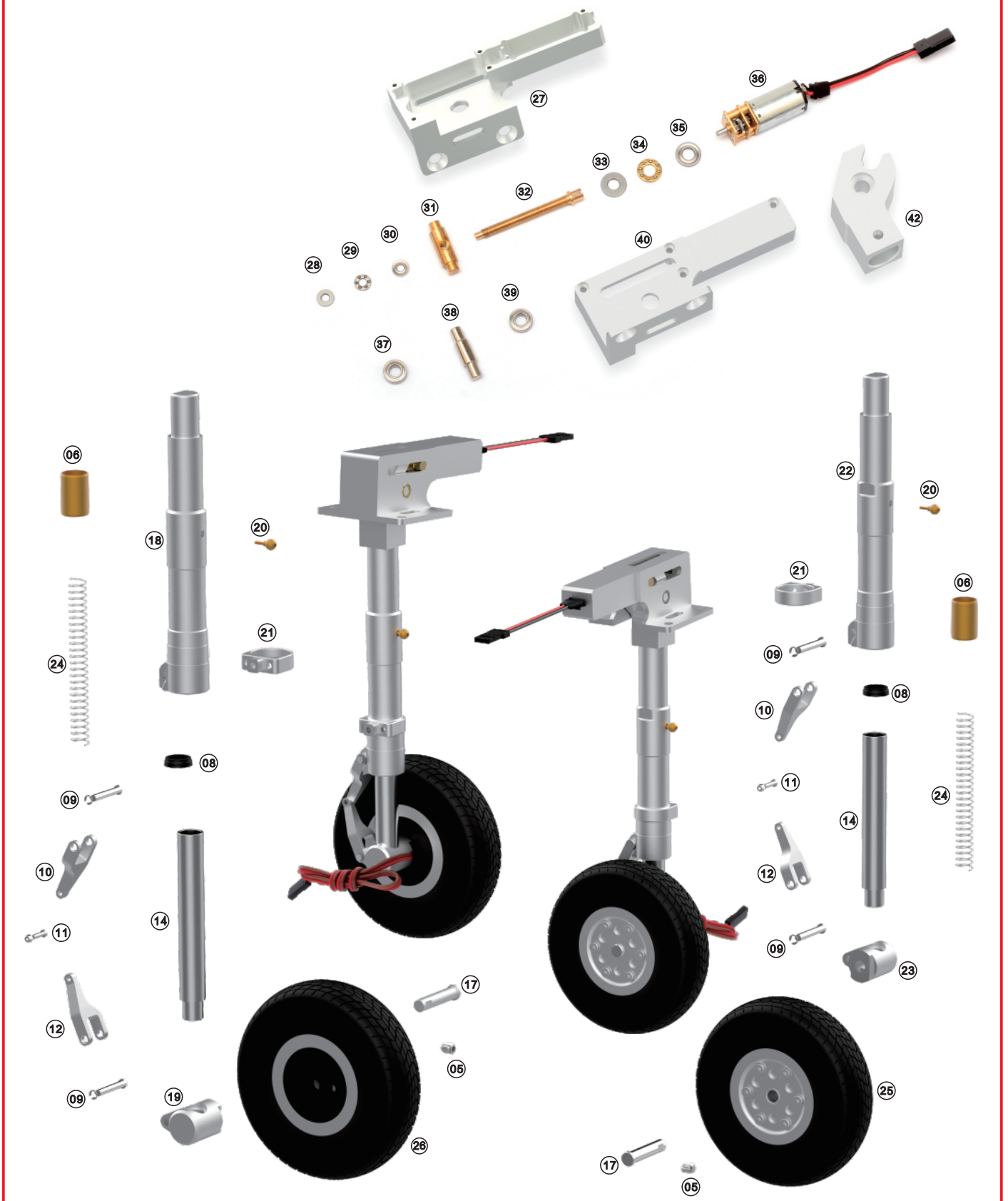

S-EDF 90mm HME-262

Specification and configuration

Specifications:

Wingspan	1890mm / 74.4 in
Length	1626mm / 64 in
Take off weight	7 kg / 15.4 lb (with 22.2V,5000mAh × 2 PCS,Li-Po)
Flying time	About 5 minutes
Main wing area	52.3 dm ²
Loading of airfoil surface	133.8 g/dm ²
Main material	35 times the import of aeromodelling EPO
Body Surface Treatment	Matte environmental water-borne paint + decal
Suitable experience level	<input type="checkbox"/> Zero basis <input type="checkbox"/> Beginner <input checked="" type="checkbox"/> Intermediate <input type="checkbox"/> Advanced
PNP assembly difficulty	<input type="checkbox"/> ☆(10mins) <input checked="" type="checkbox"/> ★☆(30mins) <input type="checkbox"/> ★★(60mins)
Operate suitable for age	Above 14 years of age
Working temperature	0°C ~ 40°C

Configuration:

Remote control channel	7CH (Selective configuration)
Control system	MFC-2085-DR
Motor	3560-1550KV (outer rotor)
EDF	S-EDF 90mm 12Blade × 2 PCS
ESC	100A × 2 PCS
Power battery	6S / 22.2V / 5000~6000mAh / 45C / Li-Po × 2 PCS (Selective configuration)
Receiver battery	2S / 7.4V / 1800~2000 mAh / Li-Po × 2 PCS (Selective configuration)
Servo	12g × 4 PCS / 25g × 9 PCS (Metal gear digital)
Landing gear	All metal hydraulic simulation electronic retractable landing gear
Brake function	Yes
LED Lighting System	Yes
Aileron	Yes
Flaps	Yes
Horizontal tail	Yes
Vertical tail	Yes
Reinforced gyro	Selective configuration
Packaging	Inner box + Outer Box (with marks 1400 × 525 × 335mm)
Center of gravity	145~150mm leading edge of main wing



HSDJETS WeChat

🌐 www.hsdr.com www.hsdedf.com www.hsdgo.com

✉ hsd@hsdjetshuangasai.com

📍 Company address : HSD Industry Park, Aigang Industry District, Huaide, Humen Town, Dongguan City, Guangdong Province, China (Post: 523926)

📍 Production address : Building F6, Standardized Factory Buildings, Xixiu Industrial Park, Xixiu District, Anshun City, Guizhou Province, China (Post: 561099)